

Comal County

OFFICE OF COMAL COUNTY ENGINEER

License to Operate On-Site Sewage Treatment and Disposal Facility

Issued This Date: **04/22/2019** Permit Number: **108589**

Location Description: **1218 LIBBY LOOKOUT
CANYON LAKE, TX 78133**

Subdivision: **The Enclave at Canyon Lake**
Unit: **2**
Lot: **59**
Block:
Acreage:

Type of System: **Aerobic
Surface Irrigation**

Issued to: **John G. Wilbur and Laura R. Wilbur**

This license is authorization for the owner to operate and maintain a private facility at the location described in accordance to the rules and regulations for on-site sewerage facilities of Comal County, Texas, and the Texas Commission on Environmental Quality.

The license grants permission to operate the facility. It does not guarantee successful operation. It is the responsibility of the owner to maintain and operate the facility in a satisfactory manner.

Alterations to this permit including, but not limited to:

- Increase in the square feet of living area
- Increase in the number of bedrooms
- A change of use (i.e. residential to commercial)
- Relocation of system components (including the relocation of spray heads)
- Installation of landscaping
- Adding new structures to the system



may require a new permit. **It is the responsibility of the owner to apply for a new permit, if applicable.**

Inspection and licensing of a facility indicates only that the facility meets certain minimum requirements. It does not impede any governmental entity in taking the proper steps to prevent or control pollution, to abate nuisance, or to protect the public health.

This license to operate is valid for an indefinite period. The holder may transfer it to a succeeding owner, provided the facility has not been remodeled and is functioning properly.

Licensing Authority

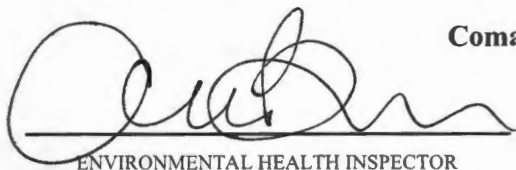
Comal County Environmental Health

ENVIRONMENTAL HEALTH INSPECTOR
ENVIRONMENTAL HEALTH COORDINATOR

OS 0025599

OS0034322

Comal County Environmental Health OSSF Inspection Sheet

Installer Name: JB Syrnics OSSF Installer #: 050018531
 1st Inspection Date: 4.15.19 2nd Inspection Date: _____ 3rd Inspection Date: _____
 Inspector Name: Cenereci A. Inspector Name: _____ Inspector Name: _____
 Permit#: 108589 Address: 1218 Libby Lookout, The Enclave @ CR

No.	Description	Answer	Citations	Notes	1st Insp.	2nd Insp.	3rd Insp.
1	SITE AND SOIL CONDITIONS & SETBACK DISTANCES Site and Soil Conditions Consistent with Submitted Planning Materials	✓	285.31(a) 285.30(b)(1)(A)(iv) 285.30(b)(1)(A)(v) 285.30(b)(1)(A)(iii) 285.30(b)(1)(A)(ii) 285.30(b)(1)(A)(i)		✓		
2	SITE AND SOIL CONDITIONS & SETBACK DISTANCES Setback Distances Meet Minimum Standards	✓	285.91(10) 285.30(b)(4) 285.31(d)		✓		
3	SEWER PIPE Proper Type Pipe from Structure to Disposal System (Cast Iron, Ductile Iron, Sch. 40, SDR 26)	✓	285.32(a)(1)		✓		
4	SEWER PIPE Slope from the Sewer to the Tank at least 1/8 Inch Per Foot	✓	285.32(a)(3)		✓		
5	SEWER PIPE Two Way Sanitary - Type Cleanout Properly Installed (Add. C/O Every 100' &/or 90 degree bends)	✓	285.32(a)(5)		✓		
6	PRETREATMENT Installed (if required) TCEQ Approved List PRETREATMENT Septic Tank(s) Meet Minimum Requirements		285.32(b)(1)(G)285.32(b)(1)(E)(iii) 285.32(b)(1)(E)(iv) 285.32(b)(1)(F) 285.32(b)(1)(B) 285.32(b)(1)(C)(i) 285.32(b)(1)(C)(ii) 285.32(b)(1)(D) 285.32(b)(1)(E) 285.32(b)(1)(A) 285.32(b)(1)(E)(ii)(II) 285.32(b)(1)(E)(i) 285.32(b)(1)(E)(ii)(I)				
7	PRETREATMENT Grease Interceptors if required for commercial		285.34(d)				

4.15.19

Tank level, set, operational
no leaks - cover all.

4.22.19

all
covered

Comal County Environmental Health OSSF Inspection Sheet

No.	Description	Answer	Citations	Notes	1st Insp.	2nd Insp.	3rd Insp.
8	SEPTIC TANK Tank(s) Clearly Marked SEPTIC TANK if Single Tank, 2 Compartments Provided with Baffle SEPTIC TANK Inlet Flowline Greater than 3" and " T " Provided on Inlet and Outlet SEPTIC TANK Septic Tank(s) Meet Minimum Requirements		285.32(b)(1)(E) 285.91(2) 285.32(b)(1)(F) 285.32(b)(1)(E)(iii) 285.32(b)(1)(E)(ii)(II) 285.32(b)(1)(E)(ii)(I) 285.32(b)(1)(E)(i) 285.32(b)(1)(D) 285.32(b)(1)(C)(ii) 285.32(b)(1)(C)(i) 285.32(b)(1)(B) 285.32(b)(1)(A) 285.32(b)(1)(E)(iv)				
9	ALL TANKS Installed on 4" Sand Cushion/ Proper Backfill Used		285.32(b)(1)(F) 285.32(b)(1)(G) 285.34(b)				
10	SEPTIC TANK Inspection / Clean Out Port & Risers Provided on Tanks Buried Greater than 12" Sealed and Capped		285.38(d)				
11	SEPTIC TANK Secondary restraint system provided SEPTIC TANK Riser permanently fastened to lid or cast into tank SEPTIC TANK Riser cap protected against unauthorized intrusions		285.38(d) 285.38(e)				
12	SEPTIC TANK Tank Volume Installed	—		see	—		
13	PUMP TANK Volume Installed	—		see 1200	—		
14	AEROBIC TREATMENT UNIT Size Installed	—		1200 SW	—		
15	AEROBIC TREATMENT UNIT Manufacturer AEROBIC TREATMENT UNIT Model Number	—		Clearstream	—		
16	DISPOSAL SYSTEM Absorptive		285.33(a)(4) 285.33(a)(1) 285.33(a)(2) 285.33(a)(3)				
17	DISPOSAL SYSTEM Leaching Chamber		285.33(a)(1) 285.33(a)(3) 285.33(a)(4) 285.33(a)(2)				
18	DISPOSAL SYSTEM Evapo-transpirative		285.33(a)(1) 285.33(a)(4) 285.33(a)(1) 285.33(a)(2)				

**Comal County Environmental Health
OSSF Inspection Sheet**

No.	Description	Answer	Citations	Notes	1st Insp.	2nd Insp.	3rd Insp.
19	DISPOSAL SYSTEM Drip Irrigation		285.33(a)(1) 285.33(a)(3) 285.33(a)(4) 285.33(a)(2)				
20	DISPOSAL SYSTEM Soil Substitution		285.33(d)(4)				
21	DISPOSAL SYSTEM Pumped Effluent		285.33(a)(3) 285.33(a)(1) 285.33(a)(2)				
22	DISPOSAL SYSTEM Gravelless Pipe		285.33(a)(3) 285.33(a)(2) 285.33(a)(4) 285.33(a)(1)				
23	DISPOSAL SYSTEM Mound		285.33(a)(3) 285.33(a)(1) 285.33(a)(2) 285.33(a)(4)				
24	DISPOSAL SYSTEM Other (describe) (Approved Design)		285.33(d)(6) 285.33(c)(4)				
25	DRAINFIELD Absorptive Drainline 3" PVC or 4" PVC						
26	DRAINFIELD Area Installed						
27	DRAINFIELD Level to within 1 inch per 25 feet and within 3 inches over entire excavation		285.33(b)(1)(A)(v)				
28	DRAINFIELD Excavation Width DRAINFIELD Excavation Depth DRAINFIELD Excavation Separation DRAINFIELD Depth of Porous Media DRAINFIELD Type of Porous Media						
29	DRAINFIELD Pipe and Gravel - Geotextile Fabric in Place		285.33(b)(1)(E)				
30	DRAINFIELD Leaching Chambers DRAINFIELD Chambers - Open End Plates w/Splash Plate, Inspection Port & Closed End Plates in Place (per manufacturers spec.)		285.33(c)(2)				
31	LOW PRESSURE DISPOSAL SYSTEM Adequate Trench Length & Width, and Adequate Separation Distance between Trenches		285.33(d)(1)(C)(i)				

**Comal County Environmental Health
OSSF Inspection Sheet**

No.	Description	Answer	Citations	Notes	1st Insp.	2nd Insp.	3rd Insp.
32	EFFLUENT DISPOSAL SYSTEM Utilized Only by Single Family Dwelling EFFLUENT DISPOSAL SYSTEM Topographic Slopes < 2.0% EFFLUENT DISPOSAL SYSTEM Adequate Length of Drain Field (1000 Linear ft. for 2 bedrooms or Less & an additional 400 ft. for each additional bedroom) EFFLUENT DISPOSAL SYSTEM Lateral Depth of 18 inches to 3 ft. & Vertical Separation of 1ft on bottom and 2 ft. to restrictive horizon and ground water respectfully EFFLUENT DISPOSAL SYSTEM Lateral Drain Pipe (1.25 - 1.5" dia.) & Pipe Holes (3/16 - 1/4" dia. Hole Size) 5 ft. Apart		285.33(b)(3)(A) 285.33(b)(3)(A) 285.33(b)(3)(B) 285.91(13) 285.33(b)(3)(D) 285.33(b)(3)(F)				
33	AEROBIC TREATMENT UNIT Is Aerobic Unit Installed According to Approved Guidelines.		285.32(c)(1)				
34	AEROBIC TREATMENT UNIT Inspection/Clean Out Port & Risers Provided AEROBIC TREATMENT UNIT Secondary restraint system provided AEROBIC TREATMENT UNIT Riser permanently fastened to lid or cast into tank AEROBIC TREATMENT UNIT Riser cap protected against unauthorized intrusions						
35	AEROBIC TREATMENT UNIT Chlorinator Properly Installed with Chlorine Tablets in Place.						
36	PUMP TANK Is the Pump Tank an approved concrete tank or other acceptable materials & construction PUMP TANK Sampling Port Provided in the Treated Effluent Line PUMP TANK Check Valve and/or Anti-Siphon Device Present When Required PUMP TANK Audible and Visual High Water Alarm Installed on Separate Circuit From Pump						
37	PUMP TANK Inspection/Clean Out Port & Risers Provided PUMP TANK Secondary restraint system provided PUMP TANK Riser permanently fastened to lid or cast into tank PUMP TANK Riser cap protected against unauthorized intrusions						
38	PUMP TANK Secondary restraint system provided						
39	PUMP TANK Electrical Connections in Approved Junction Boxes / Wiring Buried						

**Comal County Environmental Health
OSSF Inspection Sheet**

No.	Description	Answer	Citations	Notes	1st Insp.	2nd Insp.	3rd Insp.
40	APPLICATION AREA Distribution Pipe, Fitting, Sprinkler Heads & Valve Covers Color Coded Purple?		285.33(d)(2)(G)(iii)(II)285.33(d)(2)(G)(iii)(III)285.33(d)(2)(G)(v) 285.33(d)(2)(G)(iii) 285.33(d)(2)(G)(iv) 285.33(d)(2)(G)(i) 285.33(d)(2)(G)(ii) 285.33(d)(2)(G)(iii)(I)		✓		
41	APPLICATION AREA Low Angle Nozzles Used / Pressure is as required APPLICATION AREA Acceptable Area, nothing within 10 ft of sprinkler heads? APPLICATION AREA The Landscape Plan is as Designed		285.33(d)(2)(G)(j) 285.33(d)(2)(A) 285.33(d)(2)(F)		✓		
42	APPLICATION AREA Area Installed					✓	
43	PUMP TANK Meets Minimum Reserve Capacity Requirements						
44	PUMP TANK Material Type & Manufacturer						
45	PUMP TANK Type/Size of Pump Installed						

Comal County Environmental Health OSSF Inspection Sheet

Installer Name: JB Symics OSSF Installer #: 050018531
 1st Inspection Date: 4.15.19 2nd Inspection Date: _____ 3rd Inspection Date: _____
 Inspector Name: Cenereci A. Inspector Name: _____ Inspector Name: _____
 Permit#: 108589 Address: 1218 Libby Lookout, The Enclave @ CR

No.	Description	Answer	Citations	Notes	1st Insp.	2nd Insp.	3rd Insp.
1	SITE AND SOIL CONDITIONS & SETBACK DISTANCES Site and Soil Conditions Consistent with Submitted Planning Materials	✓	285.31(a) 285.30(b)(1)(A)(iv) 285.30(b)(1)(A)(v) 285.30(b)(1)(A)(iii) 285.30(b)(1)(A)(ii) 285.30(b)(1)(A)(i)		✓		
2	SITE AND SOIL CONDITIONS & SETBACK DISTANCES Setback Distances Meet Minimum Standards	✓	285.91(10) 285.30(b)(4) 285.31(d)		✓		
3	SEWER PIPE Proper Type Pipe from Structure to Disposal System (Cast Iron, Ductile Iron, Sch. 40, SDR 26)	✓	285.32(a)(1)		✓		
4	SEWER PIPE Slope from the Sewer to the Tank at least 1/8 Inch Per Foot	✓	285.32(a)(3)		✓		
5	SEWER PIPE Two Way Sanitary - Type Cleanout Properly Installed (Add. C/O Every 100' &/or 90 degree bends)	✓	285.32(a)(5)		✓		
6	PRETREATMENT Installed (if required) TCEQ Approved List PRETREATMENT Septic Tank(s) Meet Minimum Requirements		285.32(b)(1)(G)285.32(b)(1)(E)(iii) 285.32(b)(1)(E)(iv) 285.32(b)(1)(F) 285.32(b)(1)(B) 285.32(b)(1)(C)(i) 285.32(b)(1)(C)(ii) 285.32(b)(1)(D) 285.32(b)(1)(E) 285.32(b)(1)(A) 285.32(b)(1)(E)(ii)(II) 285.32(b)(1)(E)(i) 285.32(b)(1)(E)(ii)(I)				
7	PRETREATMENT Grease Interceptors if required for commercial		285.34(d)				

4.15.19
 Tank level, set, operations
 no leaks. Cover all.

**Comal County Environmental Health
OSSF Inspection Sheet**

No.	Description	Answer	Citations	Notes	1st Insp.	2nd Insp.	3rd Insp.
8	SEPTIC TANK Tank(s) Clearly Marked SEPTIC TANK If Single Tank, 2 Compartments Provided with Baffle SEPTIC TANK Inlet Flowline Greater than 3" and " T " Provided on Inlet and Outlet SEPTIC TANK Septic Tank(s) Meet Minimum Requirements		285.32(b)(1)(E) 285.91(2) 285.32(b)(1)(F) 285.32(b)(1)(E)(iii) 285.32(b)(1)(E)(ii)(II) 285.32(b)(1)(E)(ii)(I) 285.32(b)(1)(E)(i) 285.32(b)(1)(D) 285.32(b)(1)(C)(ii) 285.32(b)(1)(C)(i) 285.32(b)(1)(B) 285.32(b)(1)(A) 285.32(b)(1)(E)(iv)				
9	ALL TANKS Installed on 4" Sand Cushion/ Proper Backfill Used		285.32(b)(1)(F) 285.32(b)(1)(G) 285.34(b)				
10	SEPTIC TANK Inspection / Clean Out Port & Risers Provided on Tanks Buried Greater than 12" Sealed and Capped		285.38(d)				
11	SEPTIC TANK Secondary restraint system provided SEPTIC TANK Riser permanently fastened to lid or cast into tank SEPTIC TANK Riser cap protected against unauthorized intrusions		285.38(d) 285.38(e)				
12	SEPTIC TANK Tank Volume Installed	—		see	—		
13	PUMP TANK Volume Installed	—		see 1200	—		
14	AEROBIC TREATMENT UNIT Size Installed	—		1200 AW	—		
15	AEROBIC TREATMENT UNIT Manufacturer AEROBIC TREATMENT UNIT Model Number	—		Clearstream	—		
16	DISPOSAL SYSTEM Absorptive		285.33(a)(4) 285.33(a)(1) 285.33(a)(2) 285.33(a)(3)				
17	DISPOSAL SYSTEM Leaching Chamber		285.33(a)(1) 285.33(a)(3) 285.33(a)(4) 285.33(a)(2)				
18	DISPOSAL SYSTEM Evapo-transpirative		285.33(a)(3) 285.33(a)(4) 285.33(a)(1) 285.33(a)(2)				

**Comal County Environmental Health
OSSF Inspection Sheet**

No.	Description	Answer	Citations	Notes	1st Insp.	2nd Insp.	3rd Insp.
19	DISPOSAL SYSTEM Drip Irrigation		285.33(a)(1) 285.33(a)(3) 285.33(a)(4) 285.33(a)(2)				
20	DISPOSAL SYSTEM Soil Substitution		285.33(d)(4)				
21	DISPOSAL SYSTEM Pumped Effluent		285.33(a)(3) 285.33(a)(1) 285.33(a)(2)				
22	DISPOSAL SYSTEM Gravelless Pipe		285.33(a)(3) 285.33(a)(2) 285.33(a)(4) 285.33(a)(1)				
23	DISPOSAL SYSTEM Mound		285.33(a)(3) 285.33(a)(1) 285.33(a)(2) 285.33(a)(4)				
24	DISPOSAL SYSTEM Other (describe) (Approved Design)		285.33(d)(6) 285.33(c)(4)				
25	DRAINFIELD Absorptive Drainline 3" PVC or 4" PVC						
26	DRAINFIELD Area Installed						
27	DRAINFIELD Level to within 1 inch per 25 feet and within 3 inches over entire excavation		285.33(b)(1)(A)(v)				
28	DRAINFIELD Excavation Width DRAINFIELD Excavation Depth DRAINFIELD Excavation Separation DRAINFIELD Depth of Porous Media DRAINFIELD Type of Porous Media						
29	DRAINFIELD Pipe and Gravel - Geotextile Fabric in Place		285.33(b)(1)(E)				
30	DRAINFIELD Leaching Chambers DRAINFIELD Chambers - Open End Plates w/Splash Plate, Inspection Port & Closed End Plates in Place (per manufacturers spec.)		285.33(c)(2)				
31	LOW PRESSURE DISPOSAL SYSTEM Adequate Trench Length & Width, and Adequate Separation Distance between Trenches		285.33(d)(1)(C)(i)				

**Comal County Environmental Health
OSSF Inspection Sheet**

No.	Description	Answer	Citations	Notes	1st Insp.	2nd Insp.	3rd Insp.
32	<p>EFFLUENT DISPOSAL SYSTEM Utilized Only by Single Family Dwelling</p> <p>EFFLUENT DISPOSAL SYSTEM Topographic Slopes < 2.0%</p> <p>EFFLUENT DISPOSAL SYSTEM Adequate Length of Drain Field (1000 Linear ft. for 2 bedrooms or Less & an additional 400 ft. for each additional bedroom)</p> <p>EFFLUENT DISPOSAL SYSTEM Lateral Depth of 18 inches to 3 ft. & Vertical Separation of 1ft on bottom and 2 ft. to restrictive horizon and ground water respectfully</p> <p>EFFLUENT DISPOSAL SYSTEM Lateral Drain Pipe (1.25 - 1.5" dia.) & Pipe Holes (3/16 - 1/4" dia. Hole Size) 5 ft. Apart</p>		<p>285.33(b)(3)(A)</p> <p>285.33(b)(3)(A)</p> <p>285.33(b)(3)(B)</p> <p>285.91(13)</p> <p>285.33(b)(3)(D)</p> <p>285.33(b)(3)(F)</p>				
33	<p>AEROBIC TREATMENT UNIT Is Aerobic Unit Installed According to Approved Guidelines.</p>		285.32(c)(1)				
34	<p>AEROBIC TREATMENT UNIT Inspection/Clean Out Port & Risers Provided</p> <p>AEROBIC TREATMENT UNIT Secondary restraint system provided</p> <p>AEROBIC TREATMENT UNIT Riser permanently fastened to lid or cast into tank</p> <p>AEROBIC TREATMENT UNIT Riser cap protected against unauthorized intrusions</p>						
35	<p>AEROBIC TREATMENT UNIT Chlorinator Properly Installed with Chlorine Tablets in Place.</p>						
36	<p>PUMP TANK Is the Pump Tank an approved concrete tank or other acceptable materials & construction</p> <p>PUMP TANK Sampling Port Provided in the Treated Effluent Line</p> <p>PUMP TANK Check Valve and/or Anti- Siphon Device Present When Required</p> <p>PUMP TANK Audible and Visual High Water Alarm Installed on Separate Circuit From Pump</p>						
37	<p>PUMP TANK Inspection/Clean Out Port & Risers Provided</p> <p>PUMP TANK Secondary restraint system provided</p> <p>PUMP TANK Riser permanently fastened to lid or cast into tank</p> <p>PUMP TANK Riser cap protected against unauthorized intrusions</p>						
38	<p>PUMP TANK Secondary restraint system provided</p>						
39	<p>PUMP TANK Electrical Connections in Approved Junction Boxes / Wiring Buried</p>						

**Comal County Environmental Health
OSSF Inspection Sheet**

No.	Description	Answer	Citations	Notes	1st Insp.	2nd Insp.	3rd Insp.
40	APPLICATION AREA Distribution Pipe, Fitting, Sprinkler Heads & Valve Covers Color Coded Purple?		285.33(d)(2)(G)(iii)(II)285.33(d)(2)(G)(iii)(III)285.33(d)(2)(G)(v) 285.33(d)(2)(G)(iii) 285.33(d)(2)(G)(iv) 285.33(d)(2)(G)(i) 285.33(d)(2)(G)(ii) 285.33(d)(2)(G)(iii)(I)				
41	APPLICATION AREA Low Angle Nozzles Used / Pressure is as required APPLICATION AREA Acceptable Area, nothing within 10 ft of sprinkler heads? APPLICATION AREA The Landscape Plan is as Designed		285.33(d)(2)(G)(i) 285.33(d)(2)(A) 285.33(d)(2)(F)				
42	APPLICATION AREA Area Installed						
43	PUMP TANK Meets Minimum Reserve Capacity Requirements						
44	PUMP TANK Material Type & Manufacturer						
45	PUMP TANK Type/Size of Pump Installed						

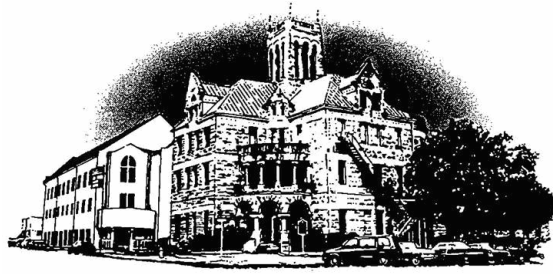

Comal County

OFFICE OF COMAL COUNTY ENGINEER

Permit of Authorization to Construct an On-Site Sewage Facility Permit Valid For One Year From Date Issued

Permit Number: 108589
Issued This Date: 01/10/2019
This permit is hereby given to: John G. Wilbur and Laura R. Wilbur

To start construction of a private, on-site sewage facility located at:

1218 LIBBY LOOKOUT
CANYON LAKE, TX 78133

Subdivision: The Enclave at Canyon Lake
Unit: 2
Lot: 59
Block:
Acreage:

APPROVED MINIMUM SIZES AS PER ATTACHED DESIGN

Type of System: Aerobic
Surface Irrigation

This permit gives permission for the construction of the above referenced on-site facility to commence. Installation must be completed by an installer holding a valid registration card from the Texas Commission on Environmental Quality (TCEQ). Installation and inspection must comply with current TCEQ and Comal County requirements.

Call (830) 608-2090 to schedule inspections.

* * * COMAL COUNTY OFFICE OF ENVIRONMENTAL HEALTH * * *
 APPLICATION FOR PERMIT FOR AUTHORIZATION TO CONSTRUCT AN
 ON-SITE SEWAGE FACILITY AND LICENSE TO OPERATE

Date 12/12/2018 Permit # 188589

Owner Name <u>John G. Wilbur and wife, Laura R. Wilbur</u>	Agent Name <u>JB Septic Systems, Inc</u>
Mailing Address <u>780 Bluff Woods Dr.</u>	Agent Address <u>P.O. Box 1609</u>
City, State, Zip <u>Driftwood, Texas 78619</u>	City, State, Zip <u>Helotes, Texas 78023</u>
Phone # <u>512-645-7566</u>	Phone # <u>830-931-0292</u>
Email <u>jgwilbur@me.com</u>	Email <u>info@jbsepticssystemsinc.com</u>

All correspondence should be sent to: Owner Agent Both Method: Mail Email

Subdivision Name The Enclave at Canyon Lake Unit 2 Lot 59 Block _____
 Acreage/Legal _____
 Street Name/Address 1218 Libby Lookout City Canyon Lake Zip 78133

Type of Development:

Single Family Residential
 Type of Construction (House, Mobile, RV, Etc.) House
 Number of Bedrooms 3
 Indicate Sq Ft of Living Area 3,868

RECEIVED
DEC 31 2018
COUNTY ENGINEER

Commercial or Institutional Facility
 (Planning materials must show adequate land area for doubling the required land needed for treatment units and disposal area)
 Type of Facility _____
 Offices, Factories, Churches, Schools, Parks, Etc. - Indicate Number Of Occupants _____
 Restaurants, Lounges, Theaters - Indicate Number of Seats _____
 Hotel, Motel, Hospital, Nursing Home - Indicate Number of Beds _____
 Travel Trailer/RV Parks - Indicate Number of Spaces _____
 Miscellaneous _____

Estimated Cost of Construction: ~~\$350,000~~ 500,000 (Structure Only) *low JGW*

Is any portion of the proposed OSSF located in the United States Army Corps of Engineers (USACE) flowage easement?
 Yes No (If yes, owner must provide approval from USACE for proposed OSSF improvements within the USACE flowage easement)

Source of Water Public Private Well

Are Water Saving Devices Being Utilized Within the Residence? Yes No

By signing this application, I certify that:

- The completed application and all additional information submitted does not contain any false information and does not conceal any material facts.
- Authorization is hereby given to the permitting authority and designated agents to enter upon the above described property for the purpose of site/soil evaluation and inspection of private sewage facilities.
- I understand that a permit of authorization to construct will not be issued until the Floodplain Administrator has performed the reviews required by the Comal County Flood Damage Prevention Ordinance.
- I affirmatively consent to the online posting/public release of my e-mail address associated with this permit application, as applicable.

Laura R. Wilbur
 Signature of Owner
John G. Wilbur

12/12/2018
 Date
12/12/18

* * * **COMAL COUNTY OFFICE OF ENVIRONMENTAL HEALTH** * * *
**APPLICATION FOR PERMIT FOR AUTHORIZATION TO CONSTRUCT AN
ON-SITE SEWAGE FACILITY AND LICENSE TO OPERATE**

RECEIVED

Planning Materials & Site Evaluation as Required Completed By Jim W. Blake, Sr. #2289

DEC 31 2018

System Description Aerobic Treatment with Spray Irrigation

Size of Septic System Required Based on Planning Materials & Soil Evaluation

COUNTY ENGINEER

Tank Size(s) (Gallons) 500/600/1,200 Absorption/Application Area (Sq Ft) 5,887

Gallons Per Day (As Per TCEQ Table III) 360

(Sites generating more than 5000 gallons per day are required to obtain a permit through TCEQ.)

Is the property located over the Edwards Recharge Zone? Yes No

(If yes, the planning materials must be completed by a Registered Sanitarian (R.S.) or Professional Engineer (P.E.))

Is there an existing TCEQ approved WPAP for the property? Yes No

(If yes, the R.S. or P.E. shall certify that the OSSF design complies with all provisions of the existing WPAP.)

If there is no existing WPAP, does the proposed development activity require a TCEQ approved WPAP? Yes No

(If yes, the R.S. or P.E. shall certify that the OSSF design will comply with all provisions of the proposed WPAP. A Permit to Construct will not be issued for the proposed OSSF until the proposed WPAP has been approved by the appropriate regional office.)

Is the property located over the Edwards Contributing Zone? Yes No

Is there an existing TCEQ approval CZP for the property? Yes No

(If yes, the P.E. or R.S. shall certify that the OSSF design complies with all provisions of the existing CZP.)

If there is no existing CZP, does the proposed development activity require a TCEQ approved CZP? Yes No

(If yes, the R.S. or P.E. shall certify that the OSSF design will comply with all provisions of the proposed CZP. A Permit to Construct will not be issued for the proposed OSSF until the CZP has been approved by the appropriate regional office.)

Is this property within an incorporated city? Yes No

If yes, indicate the city: _____

By signing this application, I certify that:

- The information provided above is true and correct to the best of my knowledge.

- I affirmatively consent to the online posting/public release of my e-mail address associated with this permit application, as applicable.

Signature of Designer

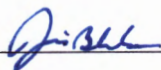

Date

12-28-18

Page 2 of 2

Wc

AFFIDAVIT TO THE PUBLIC

The County of Comal §
State of Texas §

CERTIFICATION OF OSSF REQUIRING MAINTENANCE

RECEIVED

DEC 31 2018

According to Texas Commission on Environmental Quality Rules for On-Site Sewage Facilities (OSSF's) this document is filed in the Deed Records of Comal County, Texas.

COUNTY ENGINEER

The Texas Health & Safety Code, Chapter 366 authorizes the Texas Commission on Environmental Quality (commission) to regulate on-site sewage facilities (OSSF's). Additionally, the Texas Water Code (TWC), § 5.012 and § 5.013, gives the commission primary responsibility for implementing the laws of the State of Texas relating to water and adopting rules necessary to carry out its powers and duties under the TWC. The commission, under the authority of the TWC and the Texas Health and Safety Code, requires owner's to provide notice to the public that certain types of OSSFs are located on specific pieces of property. To achieve this notice, the commission requires a recorded affidavit. Additionally, the owner must provide proof of the recording to the OSSF permitting authority. This recorded affidavit is not a representation or warranty by the commission of the suitability of this OSSF, nor does it constitute any guarantee by the commission that the appropriate OSSF was installed.

II

An OSSF requiring a maintenance contract, according to 30 Texas Administrative Code § 285.91(12) will be installed on the property described as : Lot 59, The Enclave at Canyon Lake, Unit 2, Comal County, according to plat recorded in document Number 200606033662 Map and Plat Records of Comal County, Texas.

The property is owned by John G Wilbur and wife, Laura R. Wilbur

This OSSF must be covered by a continuous maintenance contract for the first two years. After the initial two-year service policy, the owner of an aerobic treatment system for a single family residence shall either obtain a maintenance contract within 30 days or maintain the system personally.

Upon sale or transfer of the above-described property, the permit for the OSSF shall be transferred to the buyer or new owner. A copy of the planning materials for the OSSF can be obtained from the Comal County Engineer's Office.

WITNESS BY HAND(S) ON THIS 12th Day of December, 2018

John G. Wilbur
John G. Wilbur

Laura R. Wilbur
Laura R. Wilbur

SWORN TO AND SUBSCRIBED BEFORE ME ON THIS 12th DAY OF December, 2018

[Signature]
Notary Public, State of Texas

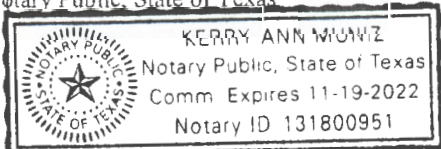

Notary's Printed Name: Kerry Ann Muniz
My Commission Expires: 11/19/22

Filed and Recorded
Official Public Records
Bobbie Koepf, County Clerk
Comal County, Texas
12/28/2018 04:25:09 PM
JESSICA 1 Page(s)
201806049127

Bobbie Koepf

**J.B. Septic Systems, Inc.
Two-Year Initial Service Policy**

Page one

**System Owner:
John & Laura Wilbur**

Brand Name: Clearstream Wastewater System
System Name: Primary
Serial Number: _____
Model Number: _____
Permit Number: _____

RECEIVED
DEC 31 2018
COUNTY ENGINEER

Site: Legal Description: 1218 Libby Lookout, Lot 59
The Enclave at Canyon Lake, Unit 2, Comal County

J. B. Septic Maintenance, Inc. will inspect and service your Clearstream Aerobic Treatment Plant once every four months for a period of two years. The effective date of this initial maintenance contract shall be the date the License to Operate is issued.

Before this initial two-year service policy expires, JB Septic Maintenance, Inc will notify you. Upon renewal of the contract, a copy of the new contract shall be submitted to the permitting authority. If the property owner or maintenance company desire to discontinue the maintenance contract, the maintenance company shall notify, in writing, the permitting authority at least 30 days prior to the date service will cease.

Testing and Reporting

- J.B. Septic Maintenance, Inc. shall test and report on this system as required by rule on the following:
1. An Inspection/Service Call every 4 months, which includes inspections, adjustment, and servicing of the mechanical and electrical component parts as necessary to ensure proper function.
 2. An effluent quality inspection every 4 months, consisting of a visual check for color, turbidity, scum overflow, and an examination for odors.
 3. A sample shall be pulled from the aeration tank every 4 months to determine if there is an excess of solids in the treatment plant. If the test results determine a need for solids removal, the user will be notified and the system will be pumped upon owner authorization.
 4. If any improper operation is observed which cannot be corrected at the time, the user shall be notified immediately in writing of the conditions and the estimated date of correction.
 5. If required, a chlorine residual test well be taken at each visit. (BOD and TSS annually on commercial only.) If a grab test is required, the Owner will be responsible for the cost of the grab test.

The owner is responsible for keeping chlorine (Bleach) in the chlorinator as well as the cost of the chlorine.

J.B. Septic Maintenance, Inc. has been certified by the manufacturer of your system, and will be responsible for fulfilling the requirements of this Maintenance Contract, as well as responding to any alarms and/or addressing any concerns by the owner of the system. Alarms and/or concerns will be addressed within 48 hours of the initial contact.

VIOLATIONS OF WARRANTY including shutting off the electric current to the system for more than 24 hours, disconnecting the alarm system, restricting ventilation to the aerator, overloading the system above its rated capacity, or introducing excessive amounts of harmful matter into the system, or any other form of unusual abuse.

RECEIVED
DEC 31 2018

Page Two COUNTY ENGINEER

This Policy Does Not Include;

1. Cost of Pumping Sludge From Unit If Necessary.
2. Cost of System Repair Due to Damage or Parts Failure Due to Neglect.
3. Cost of Replacement of "Normal Wear & Tear" Items During Routine Maintenance Visits.

The Maintenance Company and the Owner agree to abide by the service policy as stated above.

MAINTENANCE COMPANY:

J.B. Septic Maintenance, Inc.
P.O. Box 1609
Helotes, Texas 78023
(830) 931-0292
(210)414-6289

MANUFACTURER:

Clearstream Wastewater Systems, Inc.
P.O. Box 7568
Beaumont, Texas 77726-7568
(409) 755-1500

Installation Company:

J.B. Septic Systems, Inc.
P.O. Box 1609
Helotes, Texas 78023
(830) 931-0292

Permitting Authority:

Comal County Office of Environmental Health
195 David Jonas Drive
New Braunfels, TX 78132-3760
(830) 608-2094

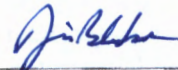

Jim Blake, J. B. Septic Systems, Inc.

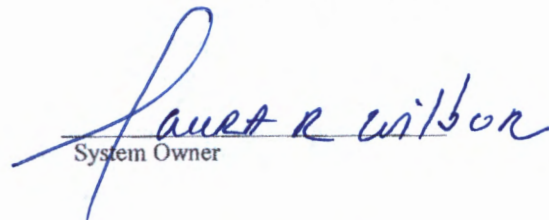

System Owner

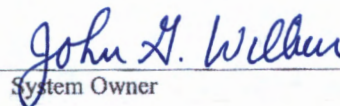

System Owner

Service Company Operator License Number: MP0000892

J. B. Septic Systems, Inc.

Jim W. Blake, Sr., RS 2289
P. O. Box 1609
Helotes, TX 78023

Telephone (830) 931-0292
Fax (830) 931-0409

November 6, 2018

Comal County Environmental Office
195 David Jonas Drive
New Braunfels, TX 78132-3760

RE: Lot 59, The Enclave at Canyon Lake, Unit 2
(1218 Libby Lookout)

To Whom It May Concern:

I hereby certify that the On-Site Sewage Facility (OSSF) design for the above referenced property complies with all provisions of the proposed Contributing Zone Plan (CZP), as approved by the Texas Commission on Environmental Quality (TCEQ).

Please contact me at the number listed above if you should have any desire to discuss this matter.

Sincerely,



Jim W. Blake, Sr.
JB Septic Systems, Inc.

RECEIVED
DEC 31 2018
COUNTY ENGINEER

J. B. Septic Systems, Inc.

Jim Blake
Registered Sanitarian
P.O. Box 1609
Helotes, Texas 78023

Office: (830) 931-0292
Fax: (830) 931-0409

SITE EVALUATION

RECEIVED

DEC 31 2018

LOCATION: 1218 Libby Lookout, Lot 59, Unit 2
The Enclave at Canyon Lake, Comal County

COUNTY ENGINEER

I. USDA County Soils Survey Classification: (CrD) Comfort-Rock Outcrop

II. Soil Analysis Sample: Unable to dig test holes due to rock.
(Method and Location)

III. Soil Profile: 0 - 10" inches clay soil with stones on and within the surface layer;
(Describe sample) underlain by limestone

IV. Soil Texture Classification:
 Soil Class Ia Soil Class Ib Soil Class II Soil Class III X Soil Class IV

V. Soil Structure: Blocky

VI. Restrictive Horizons (Note any dense clay sub-soils, rock or fractured rock, depth of groundwater etc.): Rock

VII. Topography: 1- 2 % slope

VIII. Flood Hazard: On-Site Sewage Facility is not located in a flood prone area.

IX. Overall Site Suitability: The site is suitable for Aerobic Treatment with Spray Irrigation.

X. Recharge Zone: No

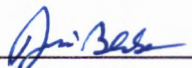
Signature

November 6, 2018
Date

OS0003914
Registration #



J.B. Septic Systems, Inc.

Jim Blake
Registered Sanitarian
P.O. Box 1609
Helotes, Texas 78023

Telephone (830) 931-0292
Fax (830) 931-0409

ON-SITE SEWAGE FACILITY DESIGN

RECEIVED

DEC 31 2018

COUNTY ENGINEER

FOR: John & Laura Wilbur
780 Bluff Woods Dr.
Driftwood, Texas 78619

LOCATION: 1218 Libby Lookout
Lot 59, Unit 2
The Enclave at Canyon Lake
Comal County

DEVELOPMENT: Proposed Three-bedroom residence with 3,868 sq. ft. living area.

ESTIMATE OF WATER CONSUMPTION: **360** gallons per day.

SEWAGE FACILITY DESCRIPTION: Clearstream Aerobic Treatment System with timer, chlorinator, sprinkler pump, and sprinkler heads covering a surface application area of 5,887 square feet. The timer is set for spray between midnight and 5:00 A.M.

CALCULATION:

$$\text{Application Area Required} = \frac{\text{Flow}}{\text{Soil Appl. Rate}} = \frac{360 \text{ Gals./Day}}{.064 \text{ Gals./Sq.Ft./Day}} = 5,625 \text{ Sq. Ft.}$$

ACTUAL APPLICATION AREA TO BE COVERED:

(Radius of Sprinkler Head) X (Radius of Sprinkler Head) X 3.14	=	Sq. Ft.
Two Full circle sprinkler heads, each one with a 25 foot radius	=	3,925 Sq. Ft
Two ½ circle sprinkler heads, each one with a 25 foot radius	=	1,962 Sq. F
Total	=	5,887 Sq. Ft.

ELECTRICAL WIRING – All wiring must be in complete compliance with 30 Texas Administrative Code 285.34(b) (4) and with the most recent National Electric Code. All electrical components should have an electrical disconnect within direct vision.

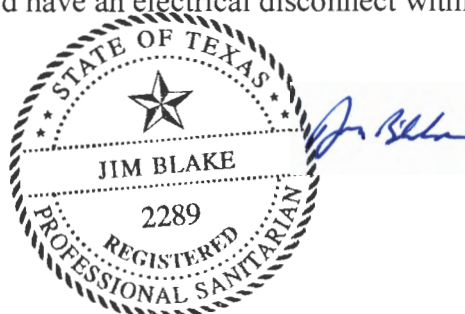

AEROBIC TREATMENT SYSTEM COMPONENTS AND REQUIREMENTS:

RECEIVED

DEC 31 2018

1. Minimum 500 gallon **Pre-Treatment Tank**.
2. **Aerobic Treatment Unit** – 600 gallon TCEQ approved unit.
3. **Liquid Chlorinator** – Only E.P.A. approved chlorine (Bleach) for use with wastewater sludge. It is the owner's responsibility to ensure that it is functioning properly and has chlorine tablets **IN IT AT ALL TIMES**.
4. 1,200 gallon **Pump Tank** with a minimum ½ horsepower, 18 GPM well pump (Clearstream P-20 pump or approved equivalent.)
5. **Sprinkler heads** must be impact or gear driven rotary design with a maximum inlet pressure of 40 PSI. Only low angle (13 degree trajectory) nozzles shall be used. All sprinkler heads shall be self-draining type so as to prevent in-line freezing. The exact location of sprinkler heads shall be coordinated between the installer and the property owner so that spray patterns shall not be blocked by trees, etc; a minimum of 10 feet shall be required between any sprinkler head and the base of a tree.
6. **SURFACE APPLICATION AREA** - The area to be sprayed shall have enough topsoil in place to cover the force lines and to support the growth of vegetation. This vegetation shall consist of grasses, evergreen shrubs, bushes, trees or landscaped beds containing mixed flora. Exposed surface rock in the application area shall be removed or covered with soil and seeded or grassed laid. Sloped land is acceptable if properly landscaped and terraced to minimize run-off. Distribution pipes and sprinkler heads must provide uniform distribution of treated effluent. The application rate must be adjusted so as to not produce run-off. Owners shall not allow driveways, fences, storage buildings, or other structures to be constructed over the treatment or disposal systems. Land that is used for growing food, gardens, orchards, or crops that may be used for human consumption, as well as unseeded bare ground, shall not be used for surface application.
7. **AFFIDAVIT** (signed and notarized) included with this design should be a permanent part of the real property deed. TCEQ requires that it give proper notification to future owners of the continuous maintenance and administrative requirements of this ATS system.
8. **MAINTENANCE CONTRACT:**

At the time of system installation, the contractor will submit to the authorized agent, (County Inspector) a copy of the 2-Year Full Service Maintenance Contract as required by the TCEQ. At the end of this period, the Service Maintenance Company will file a detailed report of the dates and findings of these inspections to the Authorized Agent. **NOTE: This system, like any other electrical appliance, requires routine, periodic inspections and maintenance to ensure continuous, trouble-free operations. Therefore, in accordance with TCEQ regulations, [Sec. 285.7 (F)] IT MUST BE KEPT UNDER CONTINUOUS MAINTENANCE COMPANY CONTRACT AT ALL TIMES FOR THE LENGTH OF THE LIFE OF THE UNIT.** This will ensure periodic inspections (at least every 4 months) for system compliance with effluent standards. Correct testing/evaluation of the unit will include periodic measuring of residual chlorine levels and/or fecal coliform analysis, as required by TCEQ. The unit, like a Conventional Septic Tank, must also be pumped at regular intervals.

NOTE: SEE ATTACHMENT for water treatment equipment and appliances installation requirements. The back flush or discharge from water treatment equipment may be discharged into an On-Site Sewage Facility as provided in this attachment. Effective April 28, 2004.

REMARKS: The contractor may make minor field adjustments to the system with approval of the county regulatory agency. The referenced site has been evaluated and the on-site sewerage facility has been designed generally following the requirements given by the Texas Commission on Environmental Quality and Comal County. The site evaluation and design are based upon technical information available today. The proper performance of any on-site sewerage facility cannot be guaranteed even though all provisions of the regulations have been met.

CERTIFICATION: I hereby certify that this sewage facility design submitted conforms to the Texas Commission on Environmental Quality and Comal County requirements, and with proper use, maintenance, and under normal climatic conditions can be expected to function without creating a nuisance.

DATE: November 6, 2018

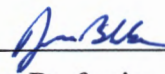

Jim Blake, Professional Sanitarian #2289



GF. NO. 256143 STEWART TITLE
ADDRESS: 1218 LIBBY LOOKOUT
CANYON LAKE, TEXAS 78133
BORROWER: JOHN G. WILBUR AND
LAURA R. WILBUR

LOT 59
THE ENCLAVE AT CANYON LAKE, UNIT 2

ACCORDING TO THE MAP OR PLAT THEREOF RECORDED
IN DOCUMENT NO. 200606033662, MAP RECORDS
OF COMAL COUNTY, TEXAS

SCALE 1" = 60'

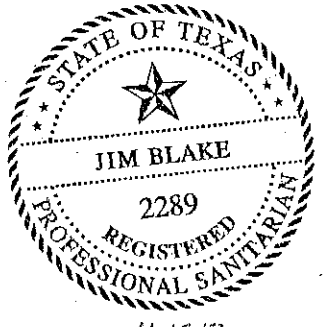
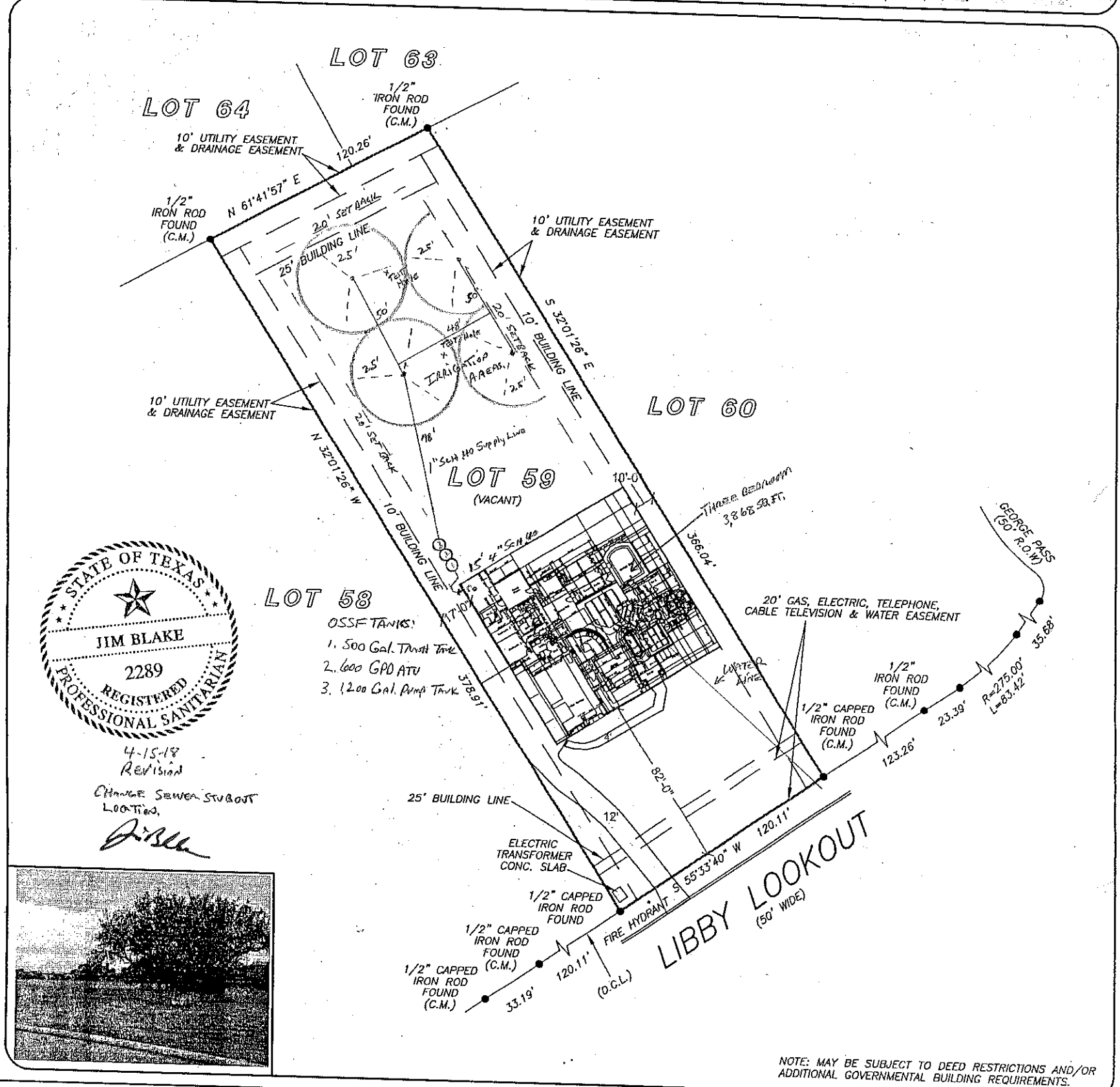

4-15-18
Revision
CHANGE SEWER SUBROUT
LOCATION
J. Blake



THIS PROPERTY DOES NOT LIE WITHIN THE
100 YEAR FLOOD PLAIN AS PER FIRM
PANEL NO. 48091C 0095 F
MAP REVISION: 09/02/2009
ZONE X
BASED ONLY ON VISUAL EXAMINATION OF MAPS.
INACCURACIES OF FEMA MAPS PREVENT EXACT
DETERMINATION WITHOUT DETAILED FIELD STUDY

A SUBSURFACE INVESTIGATION
WAS BEYOND THE SCOPE OF THIS SURVEY

D.C.L. = DIRECTIONAL CONTROL LINE
RECORD BEARING: DOC NO. 200606033662, C.C.M.R.

I HEREBY CERTIFY THAT THIS SURVEY WAS MADE
ON THE GROUND, THAT THIS PLAT CORRECTLY
REPRESENTS THE FACTS FOUND AT THE
TIME OF SURVEY AND THAT THERE ARE NO
ENCROACHMENTS APPARENT ON THE GROUND,
EXCEPT AS SHOWN HEREON. THIS SURVEY IS
CERTIFIED FOR THIS TRANSACTION ONLY AND
ABSTRACTING PROVIDED IN THE ABOVE
REFERENCED TITLE COMMITMENT WAS RELIED
UPON IN PREPARATION OF THIS SURVEY.

JAMES P. WALKOWIAK
PROFESSIONAL LAND SURVEYOR
NO. 5971
JOB NO. SA2018-02026
AUGUST 15, 2018

DRAWN BY: AC

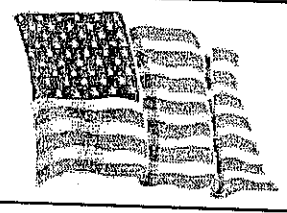
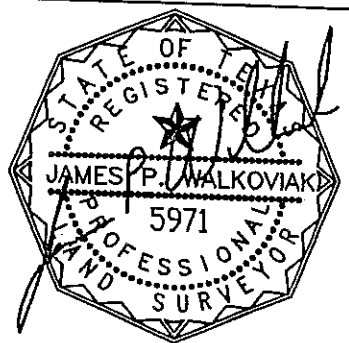

stewart
-title
BRENDA ARRAZATE
830-609-6029

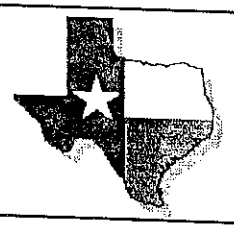

PRECISION
surveyors

1-800-LANDSURVEY
www.precisionurveyors.com
281-496-1586 FAX 281-496-1867 210-829-4941 FAX 210-829-1555
950 THREADNEEDLE STREET SUITE 150 HOUSTON, TEXAS 77079 1777 NE LOOP 410 SUITE 600 SAN ANTONIO, TEXAS 78217
FIRM NO. 10063700

STATE MANDATED REGULATION CONCERNING AEROBIC SYSTEMS

NAME: John & Laura Wilbur
LOCATION: 1218 Libby Lookout, Canyon Lake, TX 78133
DATE: November 6, 2018

RECEIVED
DEC 31 2018
COUNTY ENGINEER

As part of the installation of this system, the Texas Commission On Environmental Quality requires the following:

1. The property owner and the aerobic system maintenance contractor shall enter into a 2 year (minimum) full service maintenance contract in which the company will provide periodic inspections for system compliance with effluent standards. This contract will authorize the maintenance company to operate, maintain, and repair the system as needed. The costs of this service will be paid by the system's owner and may be included with the installation of the system. (See the attached Service Policy.)
2. The property owner shall submit an affidavit to the County Clerk's Office to be added to the Real Property Deed on which the surface application system is installed. (See the attached AFFIDAVIT TO THE PUBLIC.)
3. The maintenance company shall inspect this system as directed in the Service Policy and shall keep accurate records of their findings. These records shall be submitted to the County at the end of the first 2-year service life of the system.

DESIGN DRAWINGS

RECEIVED

DEC 31 2018

COUNTY ENGINEER

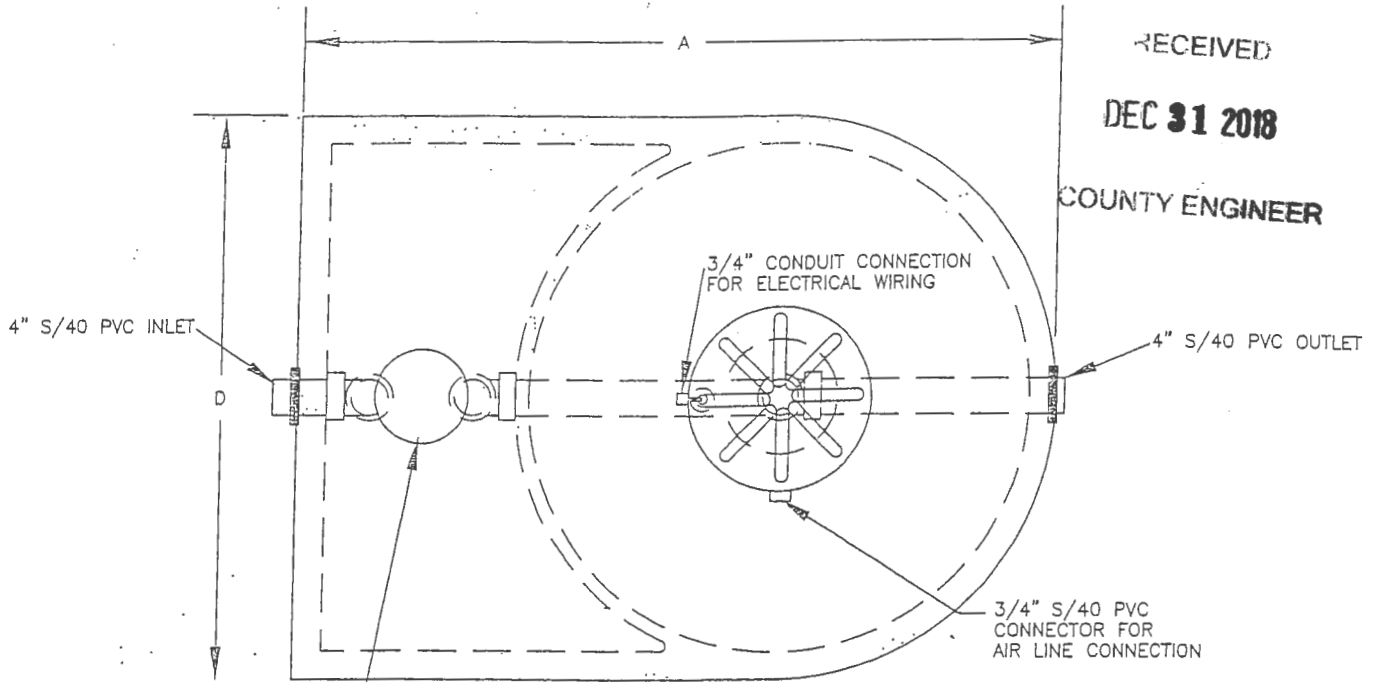

PLAN VIEW

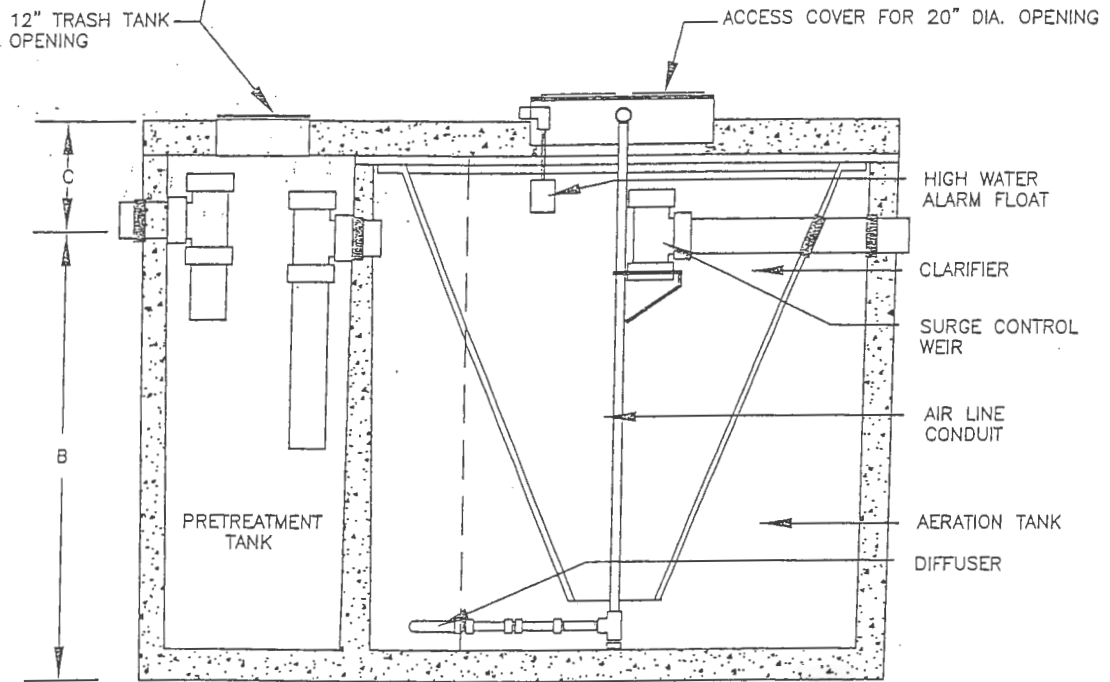

MODEL NC2
SECTION

DIMENSIONAL DATA

MODEL	A	B	C	D
500 NC2	104"	60"	10-1/2"	75"
600 NC2	107"	60"	10-1/2"	82"
750 NC2	107"	70"	10-1/2"	82"
800 NC2	107"	72"	8-1/2"	82"

RECEIVED
 DEC 31 2018
 COUNTY ENGINEER

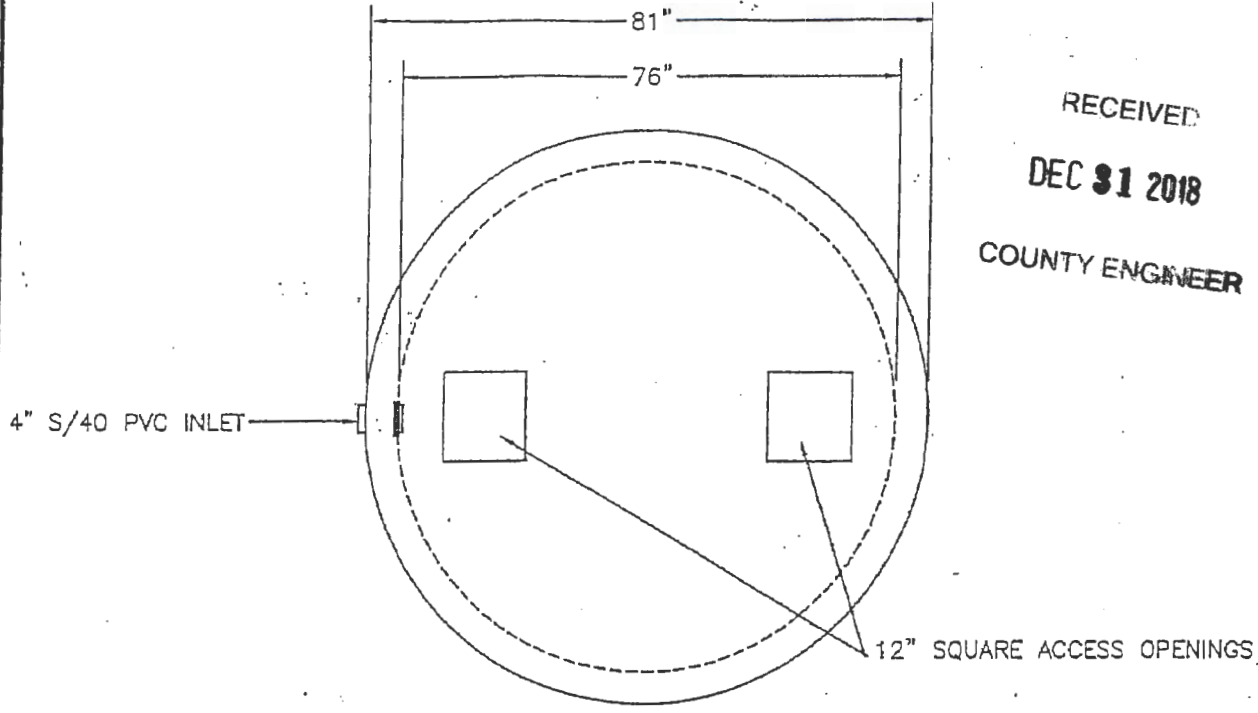

PLAN VIEW

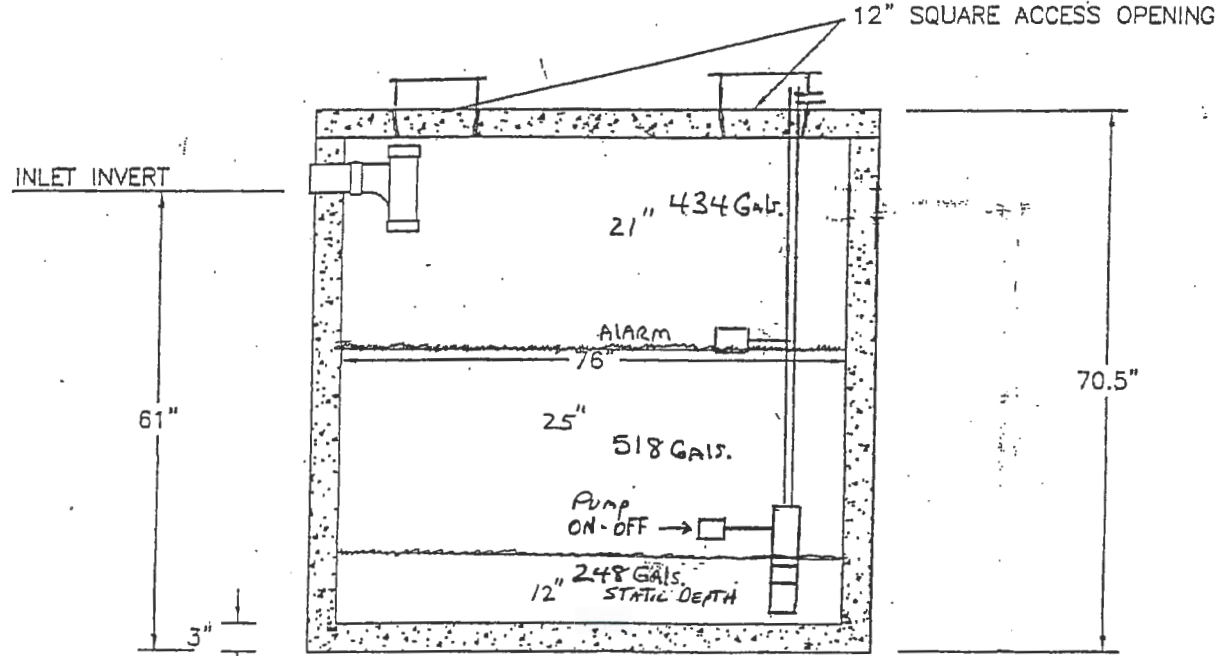

(TYP.) SECTION

NOTICE OF CONFIDENTIAL INFORMATION
 Information contained herein is confidential and is the property of Clearstream Wastewater Systems, Inc. When furnished with a proposal, the recipient shall use it solely to evaluate the proposal. When furnished to a customer, it shall be used solely for purposes of inspection, installation, or maintenance. When furnished to a supplier, it shall be used solely in the performance of work contracted for by this company. The information shall not be used or disclosed by the recipient for any other purpose whatsoever. Clearstream Wastewater Systems, Inc. retains all patent and other rights including exclusive right of use. This drawing is copyrighted and is the exclusive property of Clearstream Wastewater Systems, Inc. © Clearstream Wastewater Systems, Inc.-2008

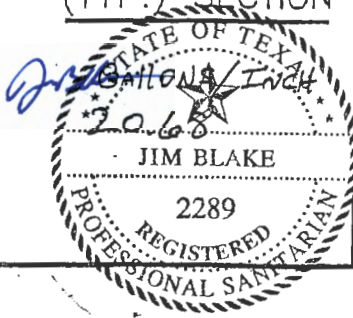

CLEARSTREAM®
 WASTEWATER SYSTEMS, INC.
 P.O. Box 9337 Beaumont, Texas 77709

1,200 GALLON PUMP TANK
 PRE-CAST CONCRETE

DRAWN:	CHKD:	DATE:	REV:	REV. DATE:	NUMBER:
CWP	JM	6/08	0	00/00	10000804

RECEIVED

DEC 31 2018

COUNTY ENGINEER



OWNER'S MANUAL

SERIES P20 4" SUBMERSIBLE PUMP

Two Wire, 1/2 HP, 115 Volt, 60 Hz

Installation • Operation

LIMITED WARRANTY

Clearstream warrants to the original consumer of the products listed below, that they will be free from defects in material and workmanship for the Warranty Period from the date of installation as noted.

<u>Product</u>	<u>Warranty Period</u>
4" Submersible Pump	2 year

Our warranty will not apply to any product that has been subject to negligence, misapplication, improper installation or maintenance.

Buyer's only remedy and Clearstream's only duty is to repair or replace defective products (at Clearstream's choice). Buyer agrees to pay all labor and shipping charges associated with this warranty and to request warranty service through the installing dealer as soon as a problem is discovered. If warranty service is requested after the Warranty Period has ended, it will not be honored.

CLEARSTREAM SHALL NOT BE LIABLE FOR ANY CONSEQUENTIAL, INCIDENTAL, OR CONTINGENT DAMAGES WHATSOEVER.

THE FOREGOING WARRANTIES ARE EXCLUSIVE AND IN LIEU OF ALL OTHER EXPRESS WARRANTIES. IMPLIED WARRANTIES, INCLUDING BUT NOT LIMITED TO THE IMPLIED WARRANTIES OF MERCHANTABILITY AND FITNESS FOR A PARTICULAR PURPOSE, SHALL NOT EXTEND BEYOND THE WARRANTY PERIOD PROVIDED HEREIN.

Certain states do not permit the exclusion or limitation of incidental or consequential damages or the placing of limitations on the duration of an implied warranty, therefore, the limitations or exclusions herein may not apply. This warranty sets forth specific legal rights and obligations, however, additional rights may exist, which may vary from state to state.

Supersedes all previous publications.

Clearstream, P.O. Box 9337, Beaumont, TX 77709

CLEARSTREAM

P.O. Box 9337, Beaumont, TX 77709

DEC 31 2018

COUNTY ENGINEER

open. Start pump. *Slowly* open valve until the desired flow rate is reached. Final setting *must* be within pump's recommended operating range.

2. Make sure that the float switches are set so that the pump stops before the pump runs dry or breaks suction. If necessary, adjust float switches to achieve this.
3. The motor bearings are lubricated internally. No maintenance is required or possible on the pump or the motor.

OPERATION

1. The pump must be submerged at all times during normal operation. Do not run pump dry.

Table 1: Recommended Fusing Data
115 Volt/60 Hz/1 Phase 2-Wire Cable

HP	Voltz/Hz/ Phase	Motor Winding Resistance Ohms	Max Load Amps	Locked Rotor Amps	Fuse Size Standard/ Dual Element
1/2	115/60/1	1.0-1.3	12.0	64.8	30/15

Table 2: Power Supply Wire (Cable) Length in Feet
1 Phase, 2 Wire Cable, 60 Hz (Copper Wire Size - Service to motor)

Volts	HP	14 AWG	12 AWG	10 AWG	8 AWG	6 AWG	4 AWG	3 AWG	2 AWG	1 AWG	0 AWG
115	1/2	100	160	250	390	620	960	1190	1460	1780	2160

1. Maximum wire lengths shown maintain motor voltage at 95% of service entrance voltage, running at maximum nameplate amperes. If service entrance voltage will be at least motor nameplate voltage under normal load conditions, 50% additional length

is permissible for all sizes.

2. Sizes given are for copper wire. For aluminum wire go two sizes larger (i.e., if table lists #12 copper wire, use #10 aluminum wire.)

Motor Insulation Resistance Readings

Normal Ohm/Megohm readings for all motors, between all leads and ground. Set ohmmeter to 100K scale.

Condition of Motor and Leads	Ohm Value	Megohm Value
New motor, without power cable	20,000,000 (or more)	20.0
Used motor, which can be reinstalled in tank	10,000,000 (or more)	10.0
Motor in Tank - Readings are Power Cable plus Motor		
New Motor	2,000,000 (or more)	2.0
Motor in reasonably good condition	500,000 to 2,000,000	0.5-2.0
Motor which may be damaged or have damaged power cable <i>Do not pull motor for these reasons</i>	20,000 to 500,000	0.02-0.5
Motor definitely damaged or with damaged power cable <i>Pull motor and repair</i>	10,000 to 20,000	0.01-0.02
Failed motor or power cable — <i>Pull motor and repair</i>	Less than 10,000	0-0.01

Important Electrical Grounding Information

⚠ WARNING

Hazardous voltage. Can shock, burn, or kill. To reduce the risk of electrical shock during pump operation, ground and bond the pump and motor as follows:

- To reduce risk of electrical shock from metal parts of the assembly other than the pump, bond together all metal parts accessible at the tank top (including metal discharge pipe, metal tank top, and the like). Use a metal bonding conductor at least as large as the power cable conductors running down the well to the pump's motor.
- Clamp or weld (or both if necessary) this bonding conductor to the grounding means provided with the pump, which will be the equip-

ment-grounding terminal, the grounding conductor on the pump housing, or an equipment-grounding lead. The equipment-grounding lead, when provided, will be the conductor having green insulation; it may also have one or more yellow stripes.

- Ground the pump, motor, and any metallic conduit that carries power cable conductors. Ground these back to the service by connecting a copper conductor from the pump, motor, and conduit to the grounding screw provided within the supply-connection box wiring compartment. This conductor must be at least as large as the circuit conductors supplying the pump.

Save these instructions.



P20

Submersible Effluent Pump

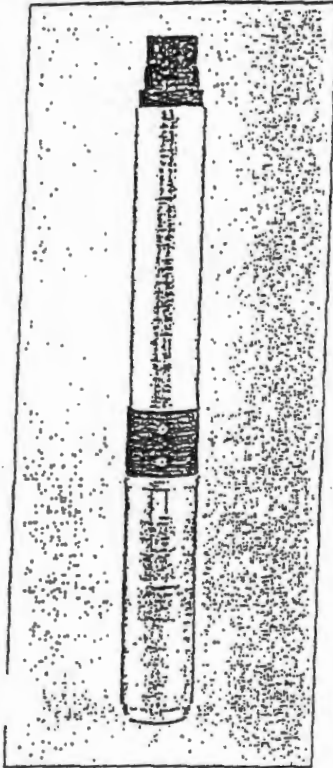

GENERAL DESCRIPTION

The P20 multistage submersible effluent pump constructed from precision-engineered, corrosion-resistant materials, is an industry leader in high pressure effluent removal. The floating stack design resists abrasion wear and reduces motor bearing thrust loading. These pumps feature the patented Signa-Seal™ design, which provides dry running capability in the event of a system failure. This patented Signa-Seal design has no industry equal.

APPLICATIONS

Designed for pumping filtered effluent.

SPECIFICATIONS

- Shell: stainless steel
- Discharge: fiberglass-reinforced thermoplastic
- Discharge bearing: Nylatron®
- Intermediate bearing: (on larger units) polycarbonate, nitrile rubber, and stainless steel
- Impellers: Delrin®
- Diffusers: Lexan®
- Suction caps: Lexan® with stainless steel insert
- Thrust pads: proprietary spec.
- Shaft and coupling: stainless steel
- Intake: fiberglass-reinforced thermoplastic
- Intake screen: polypropylene
- Cable guard: stainless steel
- Agency Listings: UL 778

FEATURES

- Patented Staging System – Our proven Signa-Seal™ staging system incorporates a harder-than-sand ceramic wear surface that when incorporated with our floating stack design, greatly reduces problems with abrasives, sand lock-up and running dry.
- Discharge – Fiberglass-reinforced thermoplastic material for durability in aggressive water. Octagon-shaped to fit pipe wrench.
- Discharge Bearing – Exclusive self-lubricating Nylatron® bearing resists wear from sand.
- Intake – Fiberglass-reinforced thermoplastic material for durability in aggressive water.
- Shaft – Positive drive from hexagonal heavy-duty 300 grade stainless steel.
- Coupling – Stainless steel press fit to pump shaft. Couples to all standard NEMA motors.
- Shell – Highest grade, heavy-walled corrosion-resistant stainless steel. Threaded for easy servicing.
- Hardware – All screws, washers and nuts are corrosion-resistant 300 grade stainless steel.
- Check Valve – Durable internal check valve.
- Cable Guard – Corrosion-resistant stainless steel guard protects motor leads. Tapered ends prevent pump from catching on wall.
- Corrosion-proof intake screen
- Franklin Electric Motor – 100% corrosion-resistant stainless steel construction. Constant lubrication through water-filled design. Hermetically-sealed stator assures moisture-free windings. Built-in surge arrester provided on 1/2 HP through 1-1/2 HP, single-phase pumps for added protection. All thrust absorbed by durable Kingsbury-type thrust bearing. Replaceable motor lead assembly. NEMA standard motors, 2- and 3-wire.

ORDERING INFORMATION

Model No.	HP	Max. Load Amps	Volts	Phase/Cycles	Cord Length
P20	1/2	12	115	1/60	100'

PERFORMANCE

Discharge Pressure PSI	67	52	44	33	19
Gallons Per Minute	10	15	20	25	30

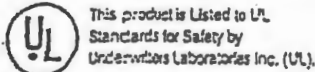

- © Nylatron is a registered trademark of Polymer Corp.
- © Lexan is a registered trademark of General Electric Co.
- © Delrin is a registered trademark of E.I. DuPont de Nemours and Co.

Specifications are subject to change without notice.



— NOTE —

We have a wide range of sump/sewage/effluent pumps to offer. If you need a catalog showing other available units, please contact your Clearstream representative.

PROPLUS® GEAR DRIVEN SPRINKLER SETTING INSTRUCTIONS

NOTE: All of our sprinklers are preset for you with a 90° arc setting, and include a pre-installed #2.5 nozzle.

CHANGING A NOZZLE

1 USE YOUR K-KEY

After you remove the nozzle retention screw with your K-Key, insert the K-Key into the keyhole on the top of the turret. Then, turn the K-Key 1/4 turn so it doesn't slip out of the hole when you pull it up.

2 PULL UP THE RISER

Firmly pull the entire spring loaded riser up with the K-Key to access the nozzle socket. Hold the riser up with one hand.

3 REMOVE THE NOZZLE

With the nozzle retention screw removed, insert the K-Key into the slot directly under the nozzle "prongs" at the top of the nozzle. Now, pivot your K-Key 1/4 of a turn to "hook" the nozzle and pull the nozzle out.

4 INSTALL A NOZZLE

Press the desired nozzle into the nozzle socket. Make sure the nozzle number is visible and the nozzle "prongs" are up. Then, re-install the nozzle retention screw. **NOTE:** The nozzle retention screw is also a break-up screw and adjusts the distance of the spray.

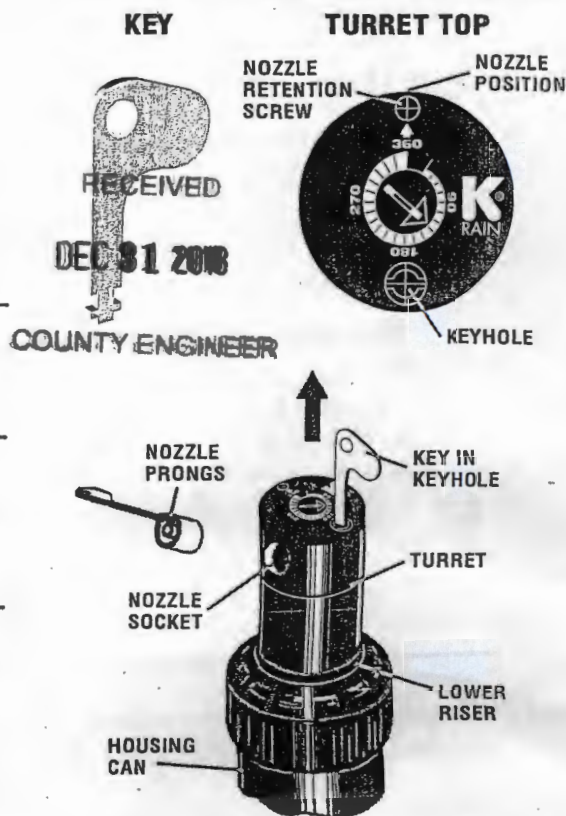

PROPLUS IS ADJUSTABLE AND CONTINUOUS 360° ALL IN ONE MODEL

SETTING THE ARC ADJUSTMENT (PRESET AT 90°)

5 FIND THE LEFT START POSITION

First, rotate the turret with your fingers around to the **RIGHT** (clockwise) until it stops. Then, rotate the turret around to the **LEFT** until it stops again. This is the **LEFT START** position. The sprinkler will begin spraying from this point and will rotate clockwise.



6 TO CHANGE THE ARC SETTING BEFORE INSTALLATION

Follow step 5 above to find the **LEFT START** as a reference point. To **INCREASE THE ARC**, insert the K-Key into the arc indication **ARROW SLOT** at the center of the turret. While holding the turret with your fingers, turn the K-Key **CLOCKWISE** until the arc **INDICATION ARROW** points to the **RIGHT STOPPING POINT**.

WHEN SET AT 360°, PROPLUS WILL ROTATE CONTINUOUSLY IN A CLOCKWISE DIRECTION.

To **DECREASE THE ARC**, hold the turret steady and turn the K-Key **COUNTERCLOCKWISE** to the desired setting.

WITH THE SPRINKLER RUNNING

Follow step 2, hand-spinning the turret gently in the direction it is spraying. Once you have found the **LEFT START** as a reference point, following the directions to **INCREASE THE ARC** or **DECREASE THE ARC** as shown above.

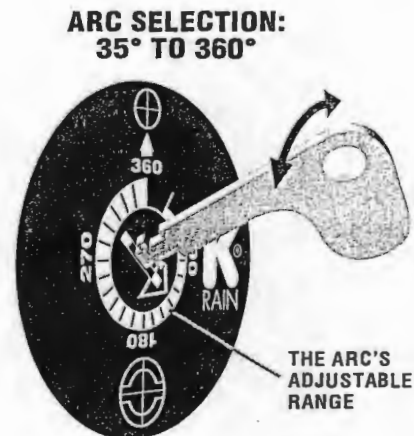

§285.37. On-Site Sewage Facilities and Water Treatment Equipment and Appliances

(a) Water treatment equipment is defined as an appliance, which includes water softeners and reverse osmosis systems, used to:

- (1) alter the mineral content of water;
- (2) alter the microbiological content of water;
- (3) alter other substances found in water; or
- (4) purify water.

RECEIVED

DEC 31 2018

COUNTY ENGINEER

(b) Back flush or discharge from water treatment equipment installed on or after September 1, 2003, may be discharged into an on-site sewage facility (OSSF) as provided in this subsection.

(1) Water softener.

(A) The water softener must regenerate using a demand-initiated regeneration (DIR) control device. The water softener must be clearly labeled as being equipped with a DIR control device as follows:

- (i) the label shall be affixed to the outside of the water softener so the label can be easily inspected and read; and
- (ii) the label shall provide the name of the company that installed the water softener.

(B) A water softener may be connected to an OSSF with a non-standard or proprietary treatment system only as described in §285.32(c) and (d) of this title (relating to Criteria for Sewage Treatment Systems) if the water softener drain line:

- (i) bypasses the treatment system; and
- (ii) connects directly to a pump tank if the OSSF has a pump tank or directly to the pipe between the treatment system and the disposal system if no pump tank exists.

(C) An owner may continue to use a water softener that discharges to an OSSF and does not meet the requirements of subparagraph (A) of this paragraph if the water softener was installed before September 1, 2003. An owner must replace any water softener installed before September 1, 2003, with a water softener that meets the requirements of subparagraphs (A) and (B) of this paragraph at such time as:

- (i) an owner replaces the existing water softener; or
- (ii) an owner or installer installs, alters, constructs, or repairs an OSSF for the structure or property served by the existing water softener.

(2) Reverse osmosis system.

(A) Point-of-use (under sink unit) reverse osmosis systems. The back flush from a point-of-use reverse osmosis system may be discharged into an OSSF without including calculations of the back flush water volume in the OSSF planning materials.

(B) Point-of-entry (whole house unit) reverse osmosis systems. The back flush from a point-of-entry reverse osmosis system may be discharged into an OSSF if:

- (i) the owner can demonstrate that the point-of-entry reverse osmosis system does not cause hydraulic overloading of the OSSF; or
- (ii) the water volume from the point-of-entry reverse osmosis system is accounted for (added to the usage rate in §285.91(3) of this title (relating to Tables)) by providing calculations of the increase in wastewater volume with the OSSF planning materials.

(3) Water treatment equipment other than water softeners and reverse osmosis systems. If an owner uses water treatment equipment other than water softeners or reverse osmosis systems, the back flush from the water treatment equipment may be discharged into an OSSF if the water volume is added to the OSSF usage rate in §285.91(3) of this title. This water volume calculation must be provided with the OSSF planning materials.

(c) Discharges from all water treatment equipment shall enter the OSSF system through an airgap or an airgap device as required in the Uniform Plumbing Code (2000).

Adopted April 7, 2004

Effective April 28, 2004



SEE PAGE 322

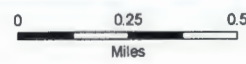

GF NO. 256143 STEWART TITLE
 ADDRESS: 1218 LIBBY LOOKOUT
 CANYON LAKE, TEXAS 78133
 BORROWER: JOHN G. WILBUR AND
 LAURA R. WILBUR

LOT 59
THE ENCLAVE AT CANYON LAKE, UNIT 2

ACCORDING TO THE MAP OR PLAT THEREOF RECORDED
 IN DOCUMENT NO. 200606033662, MAP RECORDS
 OF COMAL COUNTY, TEXAS

SCALE 1" = 60'

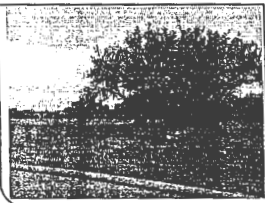
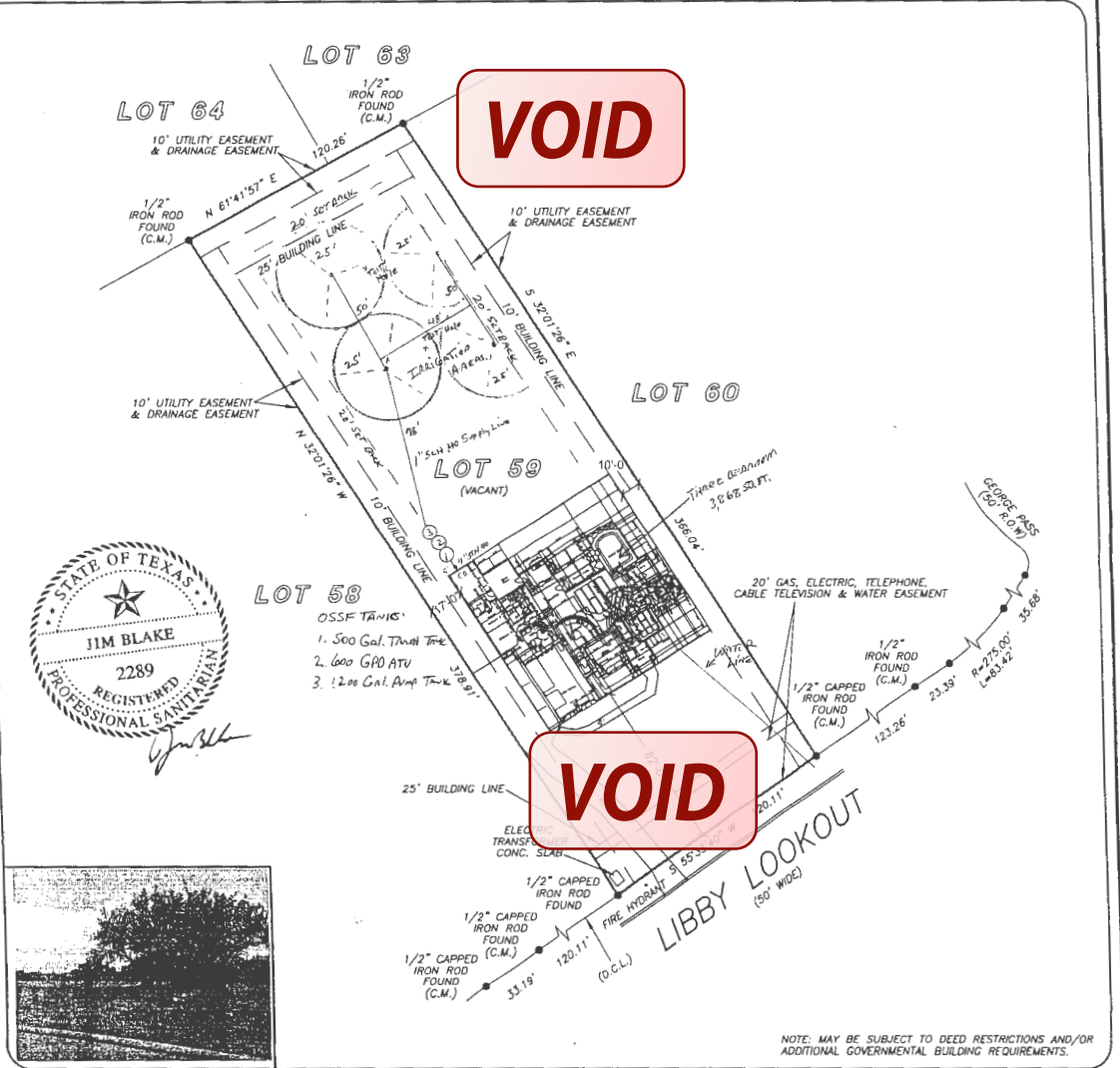

NOTE: MAY BE SUBJECT TO DEED RESTRICTIONS AND/OR
 ADDITIONAL GOVERNMENTAL BUILDING REQUIREMENTS.

THIS PROPERTY DOES NOT LIE WITHIN THE
 100 YEAR FLOOD PLAIN AS PER FIRM
 PANEL NO. 48091C 0095 F
 MAP REVISION: 09/02/2009
 ZONE X
 BASED ONLY ON VISUAL EXAMINATION OF MAPS.
 INACCURACIES OF FEMA MAPS PREVENT EXACT
 DETERMINATION WITHOUT DETAILED FIELD STUDY.

A SUBSURFACE INVESTIGATION
 WAS BEYOND THE SCOPE OF THIS SURVEY

D.C.L. = DIRECTIONAL CONTROL LINE
 RECORD BEARING: DOC NO. 200606033662, C.C.M.R.

DRAWN BY: AC

I HEREBY CERTIFY THAT THIS SURVEY WAS MADE
 ON THE GROUND, THAT THIS PLAT CORRECTLY
 REPRESENTS THE FACTS FOUND AT THE
 TIME OF SURVEY AND THAT THERE ARE NO
 ENCROACHMENTS APPARENT ON THE GROUND,
 EXCEPT AS SHOWN HEREON. THIS SURVEY IS
 CERTIFIED FOR THIS TRANSACTION ONLY AND
 ABSTRACTING PROVIDED IN THE ABOVE
 REFERENCED TITLE COMMITMENT WAS RELIED
 UPON IN PREPARATION OF THIS SURVEY.

JAMES P. WALKOVAK
 PROFESSIONAL LAND SURVEYOR
 NO. 5871
 JOB NO. SA2018-02026
 AUGUST 15, 2018



stewart
 title
BRENDA ARRAZATE
 830-609-6029



PRECISION
 surveyors

1-800-LANDSURVEY
 www.precisionurveyors.com
 281-496-1586 FAX 281-496-1867 210-829-4941 FAX 210-829-1555
 950 THREADNEEDLE STREET SUITE 150 HOUSTON, TEXAS 77079 1777 NE LOOP 410 SUITE 600 SAN ANTONIO, TEXAS 78217
 FIRM NO. 10063700

COUNTY ENGINEER

RECEIVED
 DEC 31 2018

RECEIVED

DEC 31 2018

COUNTY ENGINEER

STC256143NB

201806033282 08/24/2018 08:33:12 AM 1/2

NOTICE OF CONFIDENTIALITY RIGHTS: IF YOU ARE A NATURAL PERSON, YOU MAY REMOVE OR STRIKE ANY OR ALL OF THE FOLLOWING INFORMATION FROM ANY INSTRUMENT THAT TRANSFERS AN INTEREST IN REAL PROPERTY BEFORE IT IS FILED FOR RECORD IN THE PUBLIC RECORDS:
YOUR SOCIAL SECURITY NUMBER OR YOUR DRIVER'S LICENSE NUMBER.

GENERAL WARRANTY DEED

THE STATE OF TEXAS §
COUNTY OF COMAL § KNOW ALL MEN BY THESE PRESENTS:

THAT JEFFREY RAND VOLLMER and wife, ANNEROSE VOLLMER, hereinafter called Grantor, for and in consideration of the sum of TEN AND NO/100 DOLLARS (\$10.00) cash and other good and valuable consideration in hand paid by **JOHN G. WILBUR and wife, LAURA R. WILBUR**, hereinafter called Grantee, the receipt and sufficiency of which is hereby acknowledged;

HAS GRANTED, SOLD and CONVEYED, and by these presents does GRANT, SELL and CONVEY unto the said Grantee the following described property situated in Comal County, Texas, to-wit:

Tract 1:

Lot 59, THE ENCLAVE AT CANYON LAKE, UNIT 2, Comal County, Texas, according to plat recorded in document Number 200606033662, Map and Plat Records of Comal County, Texas.

Tract 2:

Unit 8, Building A of the CANYON LAKE AIRPORT PHASE 1, according to plat thereof contained in the Condominium Declaration and Master Deed recorded in Volume 524, pages 633-667, Document Number 200606039042 and Document Number 201706009547, Official Public Records of Comal County, Texas, together with all its undivided interest in the common elements pertaining to said units and all rights, privileges, tenements, easements, hereditaments, and appurtenances pertaining thereto, all with respect to a Condominium Project as defined by the Texas Condominium Act, including all the property, building and improvements thereto, all in accordance and subject to the aforesaid Declaration and its amendments to which Condominium Declaration and its record is here made for all purposes.

This conveyance is made subject to, all and singular, the restrictions, conditions, easements and covenants, if any, applicable to and enforceable against the above

RECEIVED
DEC 31 2018
COUNTY ENGINEER

described property as reflected by the records of the County Clerk of Comal County, Texas.

Taxes for the current year have been prorated and are thereafter assumed by Grantee.

TO HAVE AND TO HOLD the above described premises, together with, all and singular, the rights and appurtenances thereto in anywise belonging unto the said Grantee, Grantee's heirs, executors, administrators, successors, or assigns forever.

Grantor does hereby bind Grantor, Grantor's heirs, executors, administrators, and successors to warrant and forever defend, all and singular, the said premises unto the said Grantee, Grantee's heirs, executors, administrators, successors, and assigns against any person whomsoever claiming or to claim the same or any part thereof.

DATED this the 21st day of August, 2018.

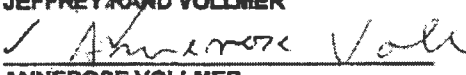
JEFFREY RAND VOLLMER

ANNEROSE VOLLMER

STATE OF FLORIDA
COUNTY OF Hillsborough

This instrument was acknowledged before me on this the 21st day of August, 2018, by JEFFREY RAND VOLLMER and wife, ANNEROSE VOLLMER.

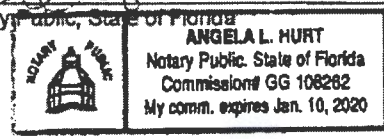
Notary Public, State of Florida



GRANTEE'S MAILING ADDRESS:
780 Bluff Woods Dr
Driftwood Tx 78619

9481.DEEEDS
Stewart Title Co. (BA)
GF #258143

Filed and Recorded
Official Public Records
Bobbie Koeppe, County Clerk
Comal County, Texas
08/24/2018 08:33:12 AM
CSCHUL 2 Pages(s)
201806033282





J.B. Septic Systems, Inc.
Two-Year Initial Service Policy

System Owner:

John & Laura Wilbur

Brand Name: Clearstream Wastewater System

System Name: Primary

Serial Number: 2310-06 NC-2TModel Number: 600 NC-2TPermit Number 108589Effective: 06/13/2019 thru 06/13/2021**Site Legal Description:** 1218 Libby Lookout, Lot 59, Unit 2The Enclave at Canyon Lake, Comal County

J. B. Septic Maintenance, Inc. will inspect and service your Clearstream Aerobic Treatment Plant once every four months for a period of two years. The service policy starts the date the "License To Operate" is issued by the permitting authority. This initial two year Service Policy will be at no additional charge to the property owner as required by State guidelines.

Before this initial two-year service policy expires, JB Septic Maintenance, Inc will notify you. Upon renewal of the contract, a copy of the new contract shall be submitted to the permitting authority. If the property owner or maintenance company desire to discontinue the maintenance contract, the maintenance company shall notify, in writing, the permitting authority at least 30 days prior to the date service will cease.

Testing and Reporting

J.B. Septic Maintenance, Inc. shall test and report on this system as required by rule on the following:

1. An Inspection/Service Call every 4 months, which includes inspections, adjustment, and servicing of the mechanical and electrical component parts as necessary to ensure proper function.
2. An effluent quality inspection every 4 months, consisting of a visual check for color, turbidity, scum overflow, and an examination for odors.
3. A sample shall be pulled from the aeration tank every 4 months to determine if there is an excess of solids in the treatment plant. If the test results determine a need for solids removal, the user will be notified and the system will be pumped upon owner authorization.
4. If any improper operation is observed which cannot be corrected at the time, the user shall be notified immediately in writing of the conditions and the estimated date of correction.
5. If required, a chlorine residual test will be taken at each visit. (BOD and TSS annually on commercial only.) If a grab test is required, the Owner will be responsible for the cost of the grab test.

The owner is responsible for keeping chlorine (Bleach) in the chlorinator as well as the cost of the chlorine.

J.B. Septic Maintenance, Inc. has been certified by the manufacturer of your system, and will be responsible for fulfilling the requirements of this Maintenance Contract, as well as responding to any alarms and/or addressing any concerns by the owner.

VIOLATIONS OF WARRANTY including shutting off the electric current to the system for more than 24 hours, disconnecting the alarm system, restricting ventilation to the aerator, overloading the system above its rated capacity, or introducing excessive amounts of harmful matter into the system, or any other form of unusual abuse.

This Policy Does Not Include;

- 1. Cost of Pumping Sludge From Unit If Necessary.
- 2. Cost of System Repair Due to Damage or Parts Failure Due to Neglect.
- 3. Cost of Replacement of "Normal Wear & Tear" Items During Routine Maintenance Visits.

The Maintenance Company and the Owner agree to abide by the service policy as stated above.

MAINTENANCE COMPANY:

J.B. Septic Maintenance, Inc.
 P.O. Box 1609
 Helotes, Texas 78023
 (830) 931-0292

Installation Company:

J.B. Septic Systems, Inc.
 P.O. Box 1609
 Helotes, Texas 78023

MANUFACTURER:

Clearstream Wastewater Systems, Inc.
 P.O. Box 7568
 Beaumont, Texas 77726-7568
 (409) 755-1500

Permitting Authority:

Comal County Office of Environmental Health
 195 David Jonas Drive
 New Braunfels, TX 78676
 (830) 608-2094

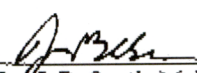

 Jim Blake, Sr., J. B. Septic Maintenance, Inc.

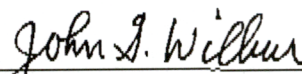

 System Owner

Service Company Operator License Number: MP0000892

Aerobic Septic System Inspection Report

Submitted by:

J. B. Septic Maintenance, Inc.

Contact: Jim Blake

Installation Date: 6/13/2019

Scheduled Report

Permit Number: 108589

This testing and reporting record shall be completed, signed and dated after each inspection. One copy shall be retained by the maintenance company. The second copy is to be sent to the local permitting authority and the third copy is to be sent to the system owner along with an invoice for services by the maintenance company.

1. Required frequency of visits is every 4 months. Date of inspection visit: 10/9/2019

2. System inspected:

Owner: John & Laura Wilbur

System Name: Primary

Property Address: 1218 Libby Lookout

Serial Num: 2310-06 NC 2T

City, State., Zip Code: Canyon Lake, TX 78133

Brand Name: Clearstream

Inspected by: Victor Alvarado

Model Num: 600 NC 2T

(Signature)

Inspected Item	Operational	Inoperative	Not Applicable
Aerators	<input checked="" type="checkbox"/>	<input type="checkbox"/>	<input type="checkbox"/>
Filters	<input checked="" type="checkbox"/>	<input type="checkbox"/>	<input type="checkbox"/>
Irrigation Pumps	<input checked="" type="checkbox"/>	<input type="checkbox"/>	<input type="checkbox"/>
Recirculation Pumps	<input type="checkbox"/>	<input type="checkbox"/>	<input checked="" type="checkbox"/>
Disinfection Device	<input checked="" type="checkbox"/>	<input type="checkbox"/>	<input type="checkbox"/>
Chlorine Supply	<input checked="" type="checkbox"/>	<input type="checkbox"/>	<input type="checkbox"/>
Electrical Circuits	<input checked="" type="checkbox"/>	<input type="checkbox"/>	<input type="checkbox"/>
Distribution System	<input checked="" type="checkbox"/>	<input type="checkbox"/>	<input type="checkbox"/>
Sprayfield Vegetation/Seedir	<input checked="" type="checkbox"/>	<input type="checkbox"/>	<input type="checkbox"/>
Other Item (Specify)	<input type="checkbox"/>	<input type="checkbox"/>	<input type="checkbox"/>

3. Repairs to system (list all components replaced):

4. Tests required and results:

Test	Required <small>Check if YES</small>	Results <small>mg/l, mpn/100 ml, or trace</small>	Test Method
BOD (Grab)	<input type="checkbox"/>	_____	_____
TSS (Grab)	<input type="checkbox"/>	_____	_____
Cl ₂ (Grab)	<input checked="" type="checkbox"/>	0.2mg/L	DPD
Fecal Coliform	<input type="checkbox"/>	_____	_____

5. Comments:

PT= "
 ATU= 10 %
 TT= " Lids secure at departure.

Aerobic Septic System Inspection Report

Submitted by:

J. B. Septic Maintenance, Inc.

Contact: Jim Blake

Installation Date: 6/13/2019

Scheduled Report

Permit Number: 108589

This testing and reporting record shall be completed, signed and dated after each inspection. One copy shall be retained by the maintenance company. The second copy is to be sent to the local permitting authority and the third copy is to be sent to the system owner along with an invoice for services by the maintenance company.

1. Required frequency of visits is every months. Date of inspection visit: 2/19/2020

2. System inspected:

Owner: John & Laura Wilbur

System Name: Primary

Property Address: 1218 Libby Lookout

Serial Num: 2310-06 NC 2T

City, State., Zip Code: Canyon Lake, TX 78133

Brand Name: Clearstream

Inspected by: Chris Ethridge

Model Num: 600 NC 2T

(Signature)

Inspected Item	Operational	Inoperative	Not Applicable
Aerators	<input checked="" type="checkbox"/>	<input type="checkbox"/>	<input type="checkbox"/>
Filters	<input checked="" type="checkbox"/>	<input type="checkbox"/>	<input type="checkbox"/>
Irrigation Pumps	<input checked="" type="checkbox"/>	<input type="checkbox"/>	<input type="checkbox"/>
Recirculation Pumps	<input type="checkbox"/>	<input type="checkbox"/>	<input checked="" type="checkbox"/>
Disinfection Device	<input checked="" type="checkbox"/>	<input type="checkbox"/>	<input type="checkbox"/>
Chlorine Supply	<input checked="" type="checkbox"/>	<input type="checkbox"/>	<input type="checkbox"/>
Electrical Circuits	<input checked="" type="checkbox"/>	<input type="checkbox"/>	<input type="checkbox"/>
Distribution System	<input checked="" type="checkbox"/>	<input type="checkbox"/>	<input type="checkbox"/>
Sprayfield Vegetation/Seedir	<input checked="" type="checkbox"/>	<input type="checkbox"/>	<input type="checkbox"/>
Other Item (Specify)	<input type="checkbox"/>	<input type="checkbox"/>	<input type="checkbox"/>

3. Repairs to system (list all components replaced):

4. Tests required and results:

<u>Test</u>	<u>Required</u> <small>Check if YES</small>	<u>Results</u> <small>mg/l, mpn/100 ml, or trace</small>	<u>Test Method</u>
BOD (Grab)	<input type="checkbox"/>	_____	_____
TSS (Grab)	<input type="checkbox"/>	_____	_____
Cl ₂ (Grab)	<input checked="" type="checkbox"/>	0.2mg/L	DPD
Fecal Coliform	<input type="checkbox"/>	_____	_____

5. Comments:

PT - 1"
 ATU - 30%
 TT - 1" Lids secured at Departure

Aerobic Septic System Inspection Report

Submitted by:

J. B. Septic Maintenance, Inc.

Contact: Jim Blake

Installation Date: 6/13/2019

Scheduled Report

Permit Number: 108589

This testing and reporting record shall be completed, signed and dated after each inspection. One copy shall be retained by the maintenance company. The second copy is to be sent to the local permitting authority and the third copy is to be sent to the system owner along with an invoice for services by the maintenance company.

1. Required frequency of visits is every 4 months. Date of inspection visit: 6/19/2020

2. System inspected:

Owner: John & Laura Wilbur

System Name: Primary

Property Address: 1218 Libby Lookout

Serial Num: 2310-06 NC 2T

City, State., Zip Code: Canyon Lake, TX 78133

Brand Name: Clearstream

Inspected by: Victor Alvarado

Model Num: 600 NC 2T

(Signature)

Inspected Item	Operational	Inoperative	Not Applicable
Aerators	<input checked="" type="checkbox"/>	<input type="checkbox"/>	<input type="checkbox"/>
Filters	<input checked="" type="checkbox"/>	<input type="checkbox"/>	<input type="checkbox"/>
Irrigation Pumps	<input checked="" type="checkbox"/>	<input type="checkbox"/>	<input type="checkbox"/>
Recirculation Pumps	<input type="checkbox"/>	<input type="checkbox"/>	<input checked="" type="checkbox"/>
Disinfection Device	<input checked="" type="checkbox"/>	<input type="checkbox"/>	<input type="checkbox"/>
Chlorine Supply	<input checked="" type="checkbox"/>	<input type="checkbox"/>	<input type="checkbox"/>
Electrical Circuits	<input checked="" type="checkbox"/>	<input type="checkbox"/>	<input type="checkbox"/>
Distribution System	<input checked="" type="checkbox"/>	<input type="checkbox"/>	<input type="checkbox"/>
Sprayfield Vegetation/Seedir	<input checked="" type="checkbox"/>	<input type="checkbox"/>	<input type="checkbox"/>
Other Item (Specify)	<input type="checkbox"/>	<input type="checkbox"/>	<input type="checkbox"/>

3. Repairs to system (list all components replaced):
replaced diffuser stone.

4. Tests required and results:

<u>Test</u>	<u>Required</u> <small>Check if YES</small>	<u>Results</u> <small>mg/l, mpr/100 ml, or trace</small>	<u>Test Method</u>
BOD (Grab)	<input type="checkbox"/>	_____	_____
TSS (Grab)	<input type="checkbox"/>	_____	_____
Cl ₂ (Grab)	<input checked="" type="checkbox"/>	0.2mg/L	DPD
Fecal Coliform	<input type="checkbox"/>	_____	_____

5. Comments:

PT = 0"
ATU = 5%
TT = 1/4 Lids secured at departure.

Aerobic Septic System Inspection Report

Submitted by:

J. B. Septic Maintenance, Inc.

Contact: Jim Blake

Installation Date: 6/13/2019

Scheduled Report

Permit Number: 108589

This testing and reporting record shall be completed, signed and dated after each inspection. One copy shall be retained by the maintenance company. The second copy is to be sent to the local permitting authority and the third copy is to be sent to the system owner along with an invoice for services by the maintenance company.

1. Required frequency of visits is ~~every~~ 11 months. Date of inspection visit: 11/2/2020

2. System inspected:

Owner: John & Laura Wilbur

System Name: Primary

Property Address: 1218 Libby Lookout

Serial Num: 2310-06 NC 2T

City, State., Zip Code: Canyon Lake, TX 78133

Brand Name: Clearstream

Inspected by: Isaac Prado

Model Num: 600 NC 2T

(Signature)

Inspected Item	Operational	Inoperative	Not Applicable
Aerators	<input checked="" type="checkbox"/>	<input type="checkbox"/>	<input type="checkbox"/>
Filters	<input checked="" type="checkbox"/>	<input type="checkbox"/>	<input type="checkbox"/>
Irrigation Pumps	<input checked="" type="checkbox"/>	<input type="checkbox"/>	<input type="checkbox"/>
Recirculation Pumps	<input type="checkbox"/>	<input type="checkbox"/>	<input checked="" type="checkbox"/>
Disinfection Device	<input checked="" type="checkbox"/>	<input type="checkbox"/>	<input type="checkbox"/>
Chlorine Supply	<input checked="" type="checkbox"/>	<input type="checkbox"/>	<input type="checkbox"/>
Electrical Circuits	<input checked="" type="checkbox"/>	<input type="checkbox"/>	<input type="checkbox"/>
Distribution System	<input checked="" type="checkbox"/>	<input type="checkbox"/>	<input type="checkbox"/>
Sprayfield Vegetation/Seedir	<input checked="" type="checkbox"/>	<input type="checkbox"/>	<input type="checkbox"/>
Other Item (Specify)	<input type="checkbox"/>	<input type="checkbox"/>	<input type="checkbox"/>

3. Repairs to system (list all components replaced):

4. Tests required and results:

<u>Test</u>	<u>Required</u> <small>Check if YES</small>	<u>Results</u> <small>mg/l, mpn/100 ml, or trace</small>	<u>Test Method</u>
BOD (Grab)	<input type="checkbox"/>		
TSS (Grab)	<input type="checkbox"/>		
Cl ₂ (Grab)	<input checked="" type="checkbox"/>	0.2mg/L	DPD
Fecal Coliform	<input type="checkbox"/>		

5. Comments:

PT= 1 "
 ATU= 5 %
 TT= 1" Lids secure at departure.

Aerobic Septic System Inspection Report

Submitted by:

J. B. Septic Maintenance, Inc.

Contact: Jim Blake

Installation Date: 6/13/2019

Scheduled Report

Permit Number: 108589

This testing and reporting record shall be completed, signed and dated after each inspection. One copy shall be retained by the maintenance company. The second copy is to be sent to the local permitting authority and the third copy is to be sent to the system owner along with an invoice for services by the maintenance company.

1. Required frequency of visits is every months.

Date of inspection visit: 8/25/2022

2. System inspected:

Owner: Steve Cossette

System Name: Primary

Property Address: 1218 Libby Lookout

Serial Num: 2310-06 NC 2T

City, State., Zip Code: Canyon Lake, TX 78133

Brand Name: Clearstream

Inspected by: Julio Esquivel

Model Num: 600 NC 2T

(Signature)

Inspected Item	Operational	Inoperative	Not Applicable
Aerators	<input checked="" type="checkbox"/>	<input type="checkbox"/>	<input type="checkbox"/>
Filters	<input checked="" type="checkbox"/>	<input type="checkbox"/>	<input type="checkbox"/>
Irrigation Pumps	<input checked="" type="checkbox"/>	<input type="checkbox"/>	<input type="checkbox"/>
Recirculation Pumps	<input type="checkbox"/>	<input type="checkbox"/>	<input checked="" type="checkbox"/>
Disinfection Device	<input checked="" type="checkbox"/>	<input type="checkbox"/>	<input type="checkbox"/>
Chlorine Supply	<input checked="" type="checkbox"/>	<input type="checkbox"/>	<input type="checkbox"/>
Electrical Circuits	<input checked="" type="checkbox"/>	<input type="checkbox"/>	<input type="checkbox"/>
Distribution System	<input checked="" type="checkbox"/>	<input type="checkbox"/>	<input type="checkbox"/>
Sprayfield Vegetation/Seedir	<input checked="" type="checkbox"/>	<input type="checkbox"/>	<input type="checkbox"/>
Other Item (Specify)		<input type="checkbox"/>	<input type="checkbox"/>

3. Repairs to system (list all components replaced):

4. Tests required and results:

<u>Test</u>	<u>Required</u> <small>Check if YES</small>	<u>Results</u> <small>mg/l, mpn/100 ml, or trace</small>	<u>Test Method</u>
BOD (Grab)	<input type="checkbox"/>	_____	_____
TSS (Grab)	<input type="checkbox"/>	_____	_____
Cl ₂ (Grab)	<input checked="" type="checkbox"/>	0.2 mg/L	DPD
Fecal Coliform	<input type="checkbox"/>	_____	_____

5. Comments:

PT= 0 "
 ATU= 10 %
 TT= 1" Lids secure at departure.



J.B. SEPTIC MAINTENANCE, INC.

SERVICE CONTRACT AGREEMENT

In consideration of the pre-payment of the **annual fee of \$ 275.00** licensed maintenance provider will provide the following services for your On-Site Sewage Facility.

- Routine service visits once every 4 months during the service period of one year from 04/11/2022 to 04/11/2023 on the Aerobic system indicated below.

Owner:	<u>Steve Cossette</u>	Phone No:	<u>(512) 299-6570</u>
System:	<u>Clearstream 600 NC 2T</u>	Permit:	<u>108589</u>
Address:	<u>1218 Libby Lookout</u>	Sub Division:	<u>The Enclave at Canyon Lake</u>
City/County:	<u>Canyon Lake/Comal</u>		

Service calls will include:

1. An effluent quality inspection consisting of a visual check for color and examination for odor.
2. Adjustment of any mechanical and electrical components that are out of order (Replacement of materials or parts is not covered).
3. Sampling of the settled solids in the aeration chamber.
4. Check chlorine residual when applicable.
5. Diffuser stones and air filters "normal wear and tear" items will be replaced as needed at an additional cost.
6. To avoid an additional trip charge, if your system needs a replacement part that is less than \$100.00, we will replace the part without authorization.

If any improper operation is observed which cannot be corrected at the time of the inspection, you shall be notified immediately in writing of the conditions and the estimated date and cost, if applicable, for correction.

At the conclusion of the service policy, J. B. Septic Maintenance, Inc. will make available, for purchase on an annual basis, a continuing service policy to cover labor for normal inspection and maintenance.

Owner / user operation instructions must be strictly followed. Also, it is the responsibility of the system owner to maintain chlorine in the system. The chlorine must be the appropriate type which is approved for waste water treatment.

J.B. Septic Maintenance, Inc. will be responsible for fulfilling the requirements of this Maintenance Contract, as well as responding to any alarms and/or addressing any concerns by the owner of the system. Alarms and/or concerns will be addressed within 48 hours of the initial contact.

Important: this service policy agreement does not cover the cost of service calls, labor or materials which are required or which are due to misuse or abuse of the system; failure to maintain electrical power to the system; disposal of non-biodegradable materials such as chemicals, solvents, grease, oil, paint, etc.; pumping of sludge build-up from the system; or any usage contrary to the requirements as stated in the "Operation Manual." Additional service, including replacement of components, laboratory test work, and pumping of tanks will be done upon customer authorization and at an additional charge.

OWNER

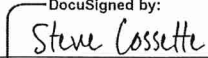
DocuSigned by:

 Signature DF97B582FBB407...

Date: 4/11/2022

SERVICE DEALER

 J.B. Septic Maintenance, Inc.